

SPIRIT®



LPG GAS GRILL OWNER'S GUIDE

E210 ORIGINAL · E310 ORIGINAL · E320 ORIGINAL



Thank you for purchasing a Weber® grill.
You've made a wise investment.
Now take a few minutes and protect it by
registering your product online at
www.weber.com®

**YOU MUST READ THIS OWNER'S GUIDE BEFORE
OPERATING YOUR GAS GRILL.**

⚠ DANGER

If you smell gas:

- 1) Shut off gas to the appliance.
- 2) Extinguish any open flames.
- 3) Open lid.
- 4) If odour continues, keep away from the appliance and immediately call your gas supplier or your fire service.

Leaking gas may cause a fire or explosion which can cause serious bodily injury, death, or damage to property.

⚠ WARNING

- 1) Do not store or use petrol or other flammable liquids or vapours in the vicinity of this or any other appliance.
- 2) A gas supply cylinder not connected for use shall not be stored in the vicinity of this or any other appliance.

⚠ **WARNING:** Carefully follow all leak-check procedures in this Owner's Guide prior to grill operation. Do this even if the grill was dealer-assembled.

⚠ **WARNING:** Do not ignite this appliance without first reading the BURNER IGNITION sections of this Owner's Guide.

OUTDOOR USE ONLY.

NOTICE TO INSTALLER:
These instructions must be left with the owner, who should keep them for future use.

CE :845CN-0003
ID: 0845

57217

EN - INTERNATIONAL ENGLISH
06/19/12

WARNINGS

⚠ DANGER

Failure to follow the DANGERS, WARNINGS and CAUTIONS contained in this Owner's Guide may result in serious bodily injury or death, or may result in a fire or an explosion causing damage to property.

WARNINGS:

- ⚠ Improper assembly of grill may be dangerous. Please follow the assembly instructions carefully.
- ⚠ Do not use this grill unless all parts are in place. The grill must be properly assembled according to the assembly instructions.
- ⚠ Your Weber® gas grill should never be used by children. Accessible parts of the grill may be very hot. Keep young children away while grill is in use.
- ⚠ Exercise caution when using your Weber® gas grill. It will be hot during cooking or cleaning, and should never be left unattended, or moved while in operation.
- ⚠ Do not use charcoal, briquettes or lava rock in your Weber® gas grill.
- ⚠ While igniting the grill or cooking, never lean over open grill.
- ⚠ Never place hands or fingers on the front edge of the cookbox when the grill is hot or the lid is open.
- ⚠ The entire cookbox gets hot when in use. Do not touch.
- ⚠ Under no circumstances should you attempt to disconnect the gas regulator or any gas fitting while your grill is in operation.
- ⚠ Use heat-resistant barbecue mitts or oven gloves when operating grill.
- ⚠ Follow regulator connection instructions for your type of gas grill.
- ⚠ Should the burners go out while grill is in operation, turn all gas valves off. Open the lid and wait five minutes before attempting to relight grill, using the igniting instructions.
- ⚠ Flammable materials should not be present within approximately 60 cm of the grill. This includes the top, bottom, back or sides of the grill.
- ⚠ Do not build this model of grill in any built-in or slide-in construction. Ignoring this WARNING could cause a fire or an explosion that can damage property and cause serious bodily injury or death.
- ⚠ Do not store an extra (spare) or disconnected gas supply cylinder under or near this grill.
- ⚠ After a period of storage and/or non-use, the Weber® gas grill should be checked for gas leaks and burner obstructions before use. See instructions in this Owner's Guide for correct procedures.
- ⚠ Do not operate your Weber® gas grill if there are any leaking gas connections.
- ⚠ Do not use a flame to check for gas leaks.
- ⚠ Do not put a grill cover or anything flammable on or in the storage area under the grill while grill is in operation or is hot.
- ⚠ Liquid propane gas is not natural gas. The conversion or attempted use of natural gas in a liquid propane gas unit or liquid propane gas in a natural gas unit is dangerous and will void your warranty.
- ⚠ Keep electrical mains lead and the fuel supply hose away from heated surfaces.
- ⚠ Do not enlarge valve orifices or burner ports when cleaning the valves or burners.
- ⚠ The Weber® gas grill should be thoroughly cleaned on a regular basis.
- ⚠ A dented or rusty gas supply cylinder may be hazardous and should be checked by your gas supplier. Do not use a gas supply cylinder with a damaged valve.
- ⚠ Although your gas supply cylinder may appear to be empty, gas may still be present, and the cylinder should be transported and stored accordingly.
- ⚠ Should a grease fire occur, turn off all burners and leave lid closed until fire is out.
- ⚠ Should an uncontrolled flare-up occur, move food away from the flames until flaring subsides.

WARRANTY

Weber-Stephen Products LLC (Weber) hereby warrants to the ORIGINAL PURCHASER of this Weber® gas grill that it will be free of defects in material and workmanship from the date of purchase as follows:

Aluminium castings:	25 years (2 years on paint; excludes fading)
Stainless steel shroud:	25 years
Porcelain-enamelled shroud:	25 years
Stainless steel burner tubes:	10 years
Stainless steel cooking grates:	5 years no rust through or burn through
Stainless steel Flavorizer® bars:	5 years no rust through or burn through
Porcelain-enamelled cast-iron cooking grates:	5 years no rust through or burn through
Porcelain-enamelled cooking grates:	3 years no rust through or burn through
Porcelain-enamelled Flavorizer® bars:	2 years no rust through or burn through
Infrared rotisserie burner:	2 years
All remaining parts:	2 years

when assembled and operated in accordance with the printed instructions accompanying it. Weber may require reasonable proof of your date of purchase. THEREFORE, YOU SHOULD RETAIN YOUR SALES RECEIPT OR INVOICE.

This Limited Warranty shall be limited to the repair or replacement of parts that prove defective under normal use and service and which on examination shall indicate, to Weber's satisfaction, they are defective. Before returning any parts, contact the Customer Service Representative in your area using the contact information on our website. If Weber confirms the defect and approves the claim, Weber will elect to replace such parts without charge. If you are required to return defective parts, transportation charges must be prepaid. Weber will return parts to the purchaser, freight or postage prepaid.

This Limited Warranty does not cover any failures or operating difficulties due to accident, abuse, misuse, alteration, misapplication, vandalism, improper installation or improper maintenance or service, or failure to perform normal and routine maintenance, including but not limited to damage caused by insects within the burner tubes, as set out in this Owner's Guide.

Deterioration or damage due to severe weather conditions such as hail, hurricanes, earthquakes or tornadoes, discoloration due to exposure to chemicals either directly or in the atmosphere, is not covered by this Limited Warranty.

There are no other express warranties except as set forth herein and any applicable implied warranties of merchantability and fitness are limited in duration to the period of coverage of this express written Limited Warranty. Some regions do not allow limitation on how long an implied warranty lasts, so this limitation may not apply to you.

Weber is not liable for any special, indirect or consequential damages. Some regions do not allow the exclusion or limitation of incidental or consequential damages, so this limitation or exclusion may not apply to you.

Weber does not authorize any person or company to assume for it any other obligation or liability in connection with the sale, installation, use, removal, return, or replacement of its equipment; and no such representations are binding on Weber.

This Warranty applies only to products sold at retail.

Visit www.weber.com®, select your country of origin, and register your grill today.

The grills illustrated in this Owner's Guide may have slight differences to the model purchased.

TABLE OF CONTENTS

WARNINGS	2
WARRANTY	3
TABLE OF CONTENTS	3
SPIRIT® E210 ORIGINAL LPG EXPLODED VIEW	4
SPIRIT® E310 ORIGINAL LPG EXPLODED VIEW	6
SPIRIT® E320 ORIGINAL LPG EXPLODED VIEW	8
IMPORTANT INFORMATION ABOUT LPG GAS & GAS CONNECTIONS	10
WHAT IS LIQUID PROPANE GAS?.....	10
SAFE HANDLING TIPS FOR LIQUID PROPANE GAS CYLINDERS.....	10
STORAGE.....	10
LPG CYLINDER REQUIREMENTS.....	10
REGULATOR CONNECTIONS & REQUIREMENTS.....	10
LPG CYLINDER INSTALLATION INSIDE CABINET	12
WHERE DOES THE LPG CYLINDER GO?.....	12
INSIDE CABINET REQUIREMENTS.....	12
INSIDE CABINET INSTALLATION.....	13
LPG CYLINDER INSTALLATION OUTSIDE CABINET	14
OUTSIDE CABINET REQUIREMENTS.....	14
GROUND PLACEMENT INSTALLATION.....	14
CONNECTING THE REGULATOR	15
WHAT IS A REGULATOR?.....	15
CONNECTING THE REGULATOR TO THE CYLINDER.....	15
PREPARING TO USE YOUR GRILL	16
WHAT IS A LEAK CHECK?.....	16
PARTIAL DISASSEMBLY OF YOUR GRILL FOR A LEAK CHECK.....	16
CHECKING FOR GAS LEAKS.....	17
DISCONNECTING THE REGULATOR.....	19
REFILLING THE LPG CYLINDER.....	19
RECONNECT THE LPG CYLINDER.....	19
GRILLING TIPS & HELPFUL HINTS	20
TIPS & HINTS.....	20
PREHEATING.....	20
COVERED COOKING.....	20
FLAVORIZER® SYSTEM.....	20
DRIPPINGS AND GREASE.....	20
SAFETY CHECKS BEFORE USING YOUR GRILL	21
SAFETY FIRST.....	21
SLIDE-OUT GREASE TRAY.....	21
CATCH PAN AND DISPOSABLE DRIP PAN.....	21
HOSE INSPECTION.....	21
MAIN BURNER IGNITION & USAGE	22
METHODS OF BURNER IGNITION.....	22
MAIN BURNER IGNITION.....	22
TO EXTINGUISH BURNER.....	22
SIDE BURNER IGNITION & USAGE (320 MODELS)	24
ON THE SIDE.....	24
SIDE BURNER IGNITION.....	24
TO EXTINGUISH SIDE BURNER.....	24
TROUBLESHOOTING	26
GENERAL TROUBLESHOOTING.....	26
SIDE BURNER TROUBLESHOOTING (320 MODEL).....	26
ANNUAL MAINTENANCE	27
KEEPING YOUR WEBER® GAS GRILL IN TIP-TOP SHAPE.....	27
BURNER FLAME PATTERN.....	27
WEBER® SPIDER/INSECT SCREENS.....	27
BURNER TUBE PORTS.....	27
BURNER TUBE CLEANING OR REPLACEMENT.....	28
STORAGE.....	32
ROUTINE MAINTENANCE	33
BEAUTIFUL—INSIDE AND OUT.....	33
CLEANING THE OUTSIDE OF THE GRILL.....	33
CLEANING THE INSIDE OF THE GRILL.....	33
HOSE INSPECTION.....	33
MAINTAINING THE ELECTRONIC CROSSOVER® IGNITION SYSTEM.....	34
CLEANING SIDE BURNER TUBE (320 MODEL).....	35
SIDE BURNER MAINTENANCE.....	35

SPiRiT® E210 ORIGINAL LPG EXPLODED VIEW

Spirit_E210_Original_LPG_EU_030412

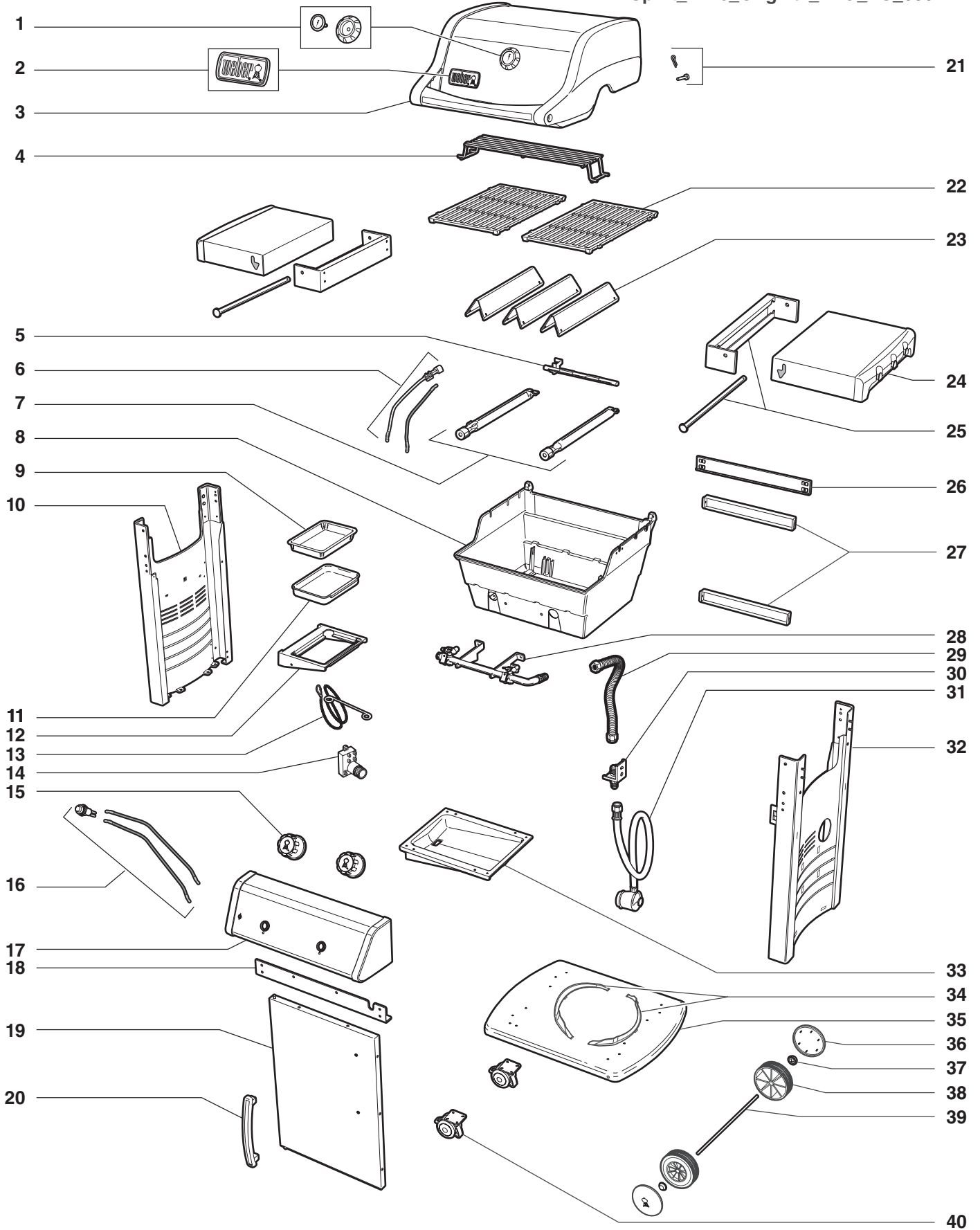

SPIRIT® E210 ORIGINAL LPG EXPLODED VIEW

SPIRIT® E210 ORIGINAL LPG EXPLODED VIEW LIST

1. Thermometer and Bezel
2. Logo Plate
3. Shroud Assembly
4. Warming Rack
5. Crossover® Burner Tube
6. Igniter Electrode
7. Burner Tube
8. Cookbox
9. Disposable Drip Pan
10. Left Frame Panel
11. Catch Pan
12. Catch Pan Holder
13. Matchstick Holder
14. Igniter Module
15. Control Knob
16. Igniter Button
17. Control Panel
18. Front Cross Brace
19. Door
20. Door Handle
21. Shroud Hardware
22. Cooking Grate
23. Flavorizer® Bar
24. Fold-Down Side Table
25. Fold-Down Assembly
26. Rear Cross Brace
27. Rear Frame Support
28. Manifold
29. Manifold Hose
30. Bulkhead
31. Hose & Regulator
32. Right Frame Panel
33. Slide-Out Grease Tray
34. Cylinder Bracket
35. Bottom Panel
36. Wheel Cover
37. Hub Cap
38. Wheel
39. Axle
40. Locking Caster

SPiRiT® E310 ORIGINAL LPG EXPLODED VIEW

Spirit_E310_Original_LPG_EU_030412

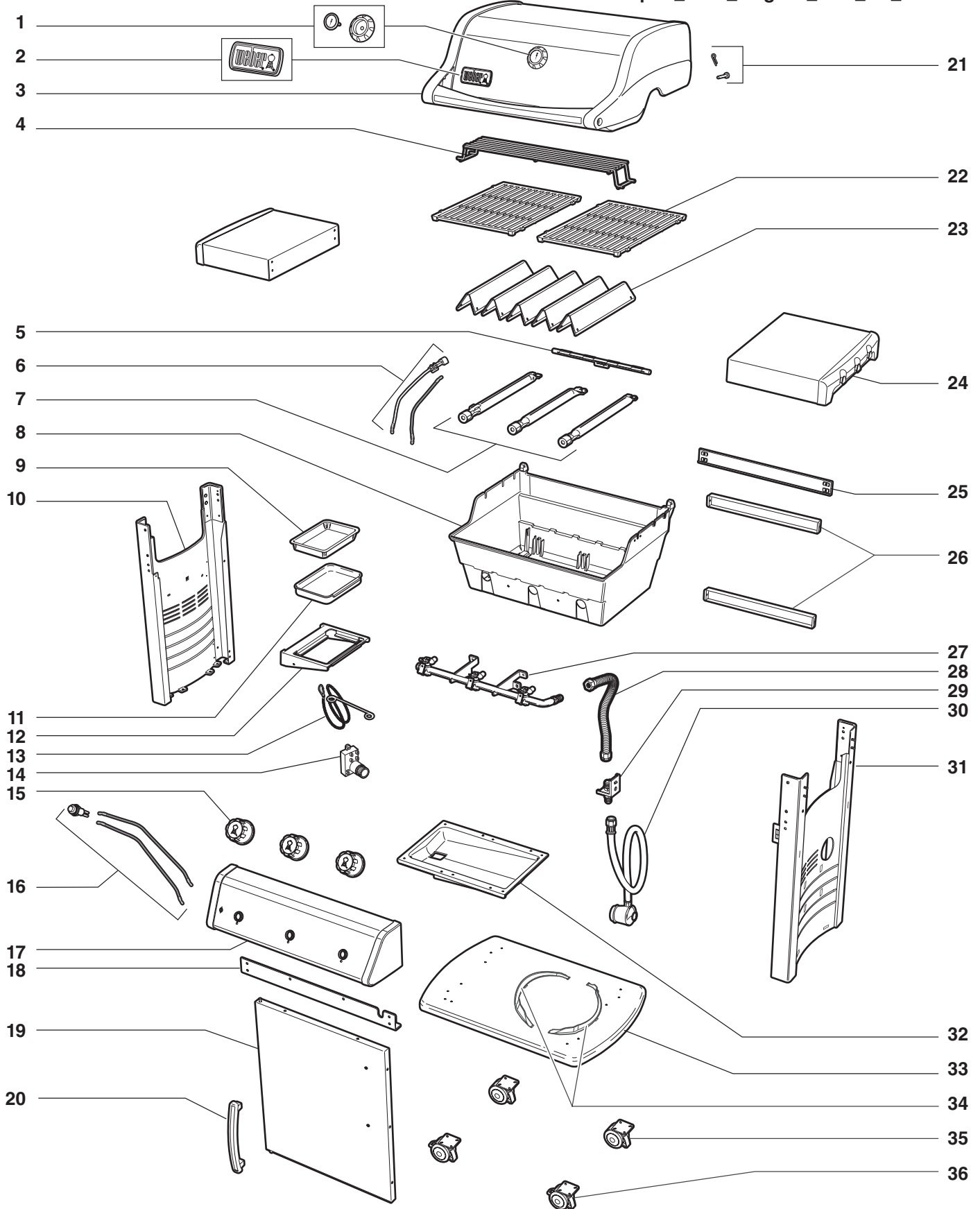

SPIRIT® E310 ORIGINAL LPG EXPLODED VIEW

SPIRIT® E310 ORIGINAL LPG EXPLODED VIEW LIST

1. Thermometer and Bezel
2. Logo Plate
3. Shroud Assembly
4. Warming Rack
5. Crossover® Burner Tube
6. Igniter Electrode
7. Burner Tube
8. Cookbox
9. Disposable Drip Pan
10. Left Frame Panel
11. Catch Pan
12. Catch Pan Holder
13. Matchstick Holder
14. Igniter Module
15. Control Knob
16. Igniter Button
17. Control Panel
18. Front Cross Brace
19. Door
20. Door Handle
21. Shroud Hardware
22. Cooking Grate
23. Flavorizer® Bar
24. Side Table
25. Rear Cross Brace
26. Rear Frame Support
27. Manifold
28. Manifold Hose
29. Bulkhead
30. Hose & Regulator
31. Right Frame Panel
32. Slide-Out Grease Tray
33. Bottom Panel
34. Cylinder Bracket
35. Caster
36. Locking Caster

SPiRiT® E320 ORIGINAL LPG EXPLODED VIEW

Spirit_E320_Original_LPG_EU_030412

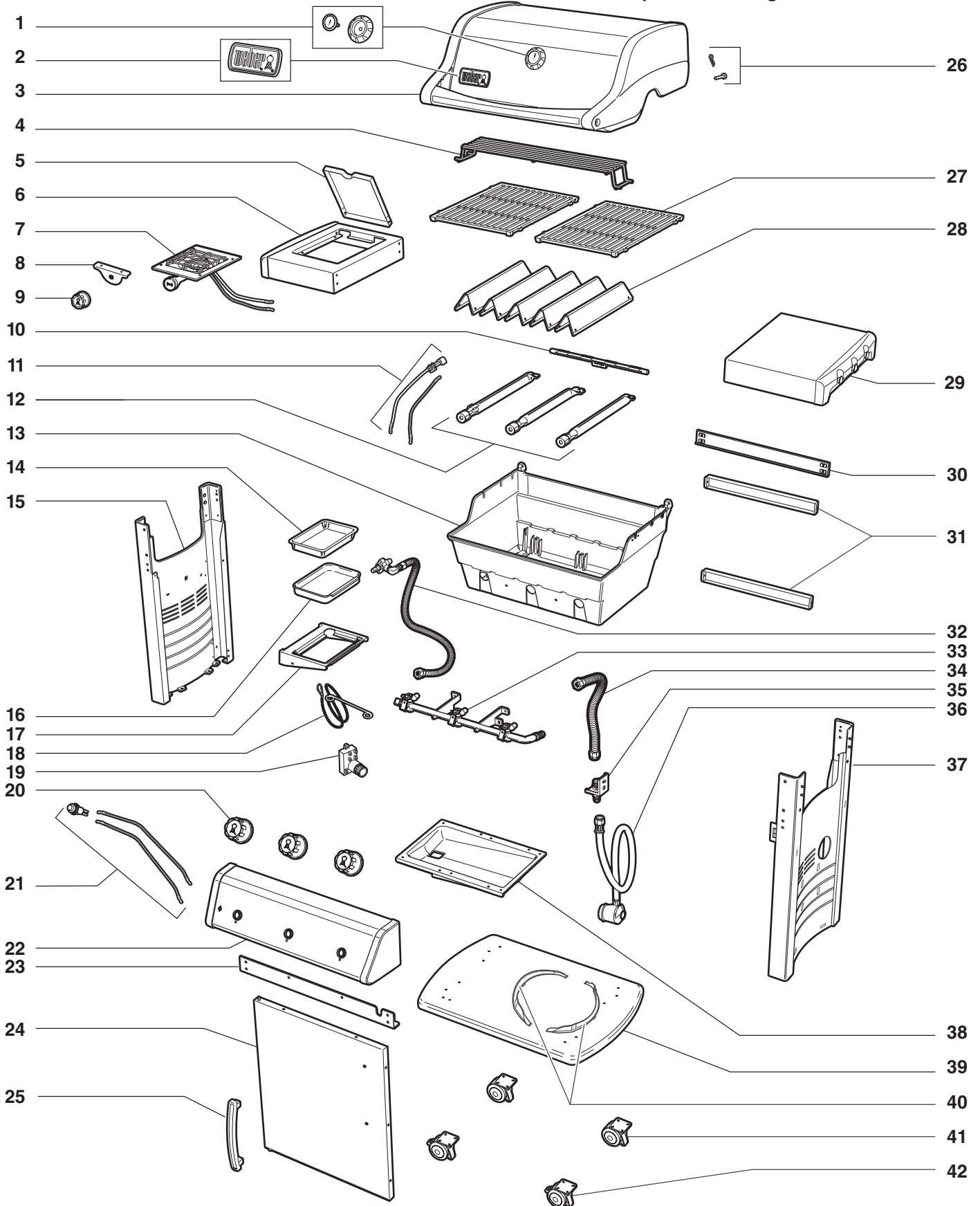

SPIRIT® E320 ORIGINAL LPG EXPLODED VIEW

SPIRIT® E320 ORIGINAL LPG EXPLODED VIEW LIST

1. Thermometer and Bezel
2. Logo Plate
3. Shroud Assembly
4. Warming Rack
5. Side Burner Lid
6. Side Burner Table
7. Side Burner Assembly
8. Side Burner Valve Plate
9. Side Burner Control Knob
10. Crossover® Burner Tube
11. Igniter Electrode
12. Burner Tube
13. Cookbox
14. Disposable Drip Pan
15. Left Frame Panel
16. Catch Pan
17. Catch Pan Holder
18. Matchstick Holder
19. Igniter Module
20. Control Knob
21. Igniter Button
22. Control Panel
23. Front Cross Brace
24. Door
25. Door Handle
26. Shroud Hardware
27. Cooking Grate
28. Flavorizer® Bar
29. Side Table
30. Rear Cross Brace
31. Rear Frame Support
32. Side Burner Gas Line Assembly
33. Manifold
34. Manifold Hose
35. Bulkhead
36. Hose & Regulator
37. Right Frame Panel
38. Slide-Out Grease Tray
39. Bottom Panel
40. Cylinder Bracket
41. Caster
42. Locking Caster

WHAT IS LIQUID PROPANE GAS?

Liquid propane gas (LPG) is the flammable, petroleum-based product used to fuel your grill. It is a gas at moderate temperatures and pressure when it is not contained. But at moderate pressure inside a container, such as a cylinder, LPG is a liquid. As pressure is released from the cylinder, the liquid readily vapourises and becomes liquid propane gas.

- LPG has an odour similar to natural gas. You should be aware of this odour.
- LPG is heavier than air. Leaking liquid propane gas may collect in low areas and resist dispersion.

SAFE HANDLING TIPS FOR LIQUID PROPANE GAS CYLINDERS

There are various guidelines and safety factors that you need to keep in mind when using liquid propane gas (LPG). Carefully follow these instructions before using your Weber® gas grill.

- Always close the cylinder valve before disconnecting regulator.
- Do not use a damaged LPG cylinder. A dented or rusty LPG cylinder or an LPG cylinder with a damaged valve may be hazardous and should be replaced with a new cylinder immediately.
- Treat "empty" LPG cylinders with the same care as you treat full cylinders. Even when an LPG cylinder is empty of liquid, there may still be gas pressure inside the cylinder.
- LPG cylinders must be installed, transported, and stored in an upright position. LPG cylinders should not be dropped or handled roughly.
- Never store or transport the LPG cylinder where temperatures can reach 51° C (the cylinder will become too hot to hold by hand). For example: do not leave the LPG cylinder in a car on a hot day.
- Leak-test the joint where the regulator connects to the LPG cylinder each time a reconnection occurs. For example: test each time the LPG cylinder is refilled and reinstalled.
- LPG cylinders must be kept out of reach of children.
- Do not connect to natural gas supply (city gas). The valves and orifices are designed exclusively for liquid propane gas.
- The areas around the LPG cylinder must be free and clear from debris.
- The LPG cylinder should not be changed in the proximity of an ignition source.

STORAGE

For grills that have been stored for a while, it is important to follow these guidelines:

- The gas must be turned off at the LPG cylinder when the Weber® gas grill is not in use.

⚠ WARNING: Make sure that the LPG cylinder valve is closed when the grill is not in use.

- If storing the Weber® gas grill indoors, first DISCONNECT the gas supply and store the LPG cylinder outdoors in a well-ventilated space.
- Do not store a disconnected LPG cylinder in a building, garage, or any other enclosed area.
- If you do not disconnect the LPG cylinder from the Weber® gas grill, be sure to keep both the grill and the cylinder outdoors in a well-ventilated area.
- Check that the areas under the control panel and the slide-out grease tray are free from debris that might obstruct the flow of combustion or ventilation air.

LPG CYLINDER REQUIREMENTS

- Use only a 3kg-13kg LPG cylinder.

REGULATOR CONNECTIONS & REQUIREMENTS

- In the United Kingdom, this appliance must be fitted with a regulator complying with BS 3016, having a nominal output of 37 millibars. (Supplied with grill.)
- The length of hose must not exceed 1.5 metres.
- Avoid kinking the hose.
- We recommend that you replace the gas hose on your Weber® gas grill every five years. Some countries may have requirements that the gas hose be replaced within less than five years, in which case that country's requirement would take precedence.
- Any parts sealed by the manufacturer must not be altered by the user.
- Any modification of the appliance may be dangerous.
- Only a nationally approved low-pressure hose and regulator must be used.
- Replacement pressure regulators and hose assemblies must be those specified by the outdoor cooking gas appliance manufacturer.
- Be sure the regulator is mounted with the small vent hole pointed downward so that it will not collect water. This vent should be free of dirt, grease, bugs, etc.

IMPORTANT INFORMATION ABOUT LPG GAS & GAS CONNECTIONS

COUNTRY	GAS TYPE & PRESSURE
Bulgaria, Cyprus, Czech Republic, Denmark, Estonia, Finland, Hungary, Iceland, Latvia, Lithuania, Malta, Netherlands, Norway, Romania, Slovak Republics, Slovenia, Spain, Sweden, Turkey	I ₃ B/P - 30 mbar
Belgium, France, Greece, Ireland, Italy, Luxembourg, Portugal, Switzerland, United Kingdom	I ₃₊ - 28-30 / 37 mbar
Poland	I ₃ B/P - 37 mbar
Austria, Germany	I ₃ B/P - 50 mbar

CONSUMPTION DATA				
	Propane kW	Butane kW	Propane g/h	Butane g/h
Spirit® 210 Classic	7,8	8,8	558	640
Spirit® 310 Classic	9,4	10,6	672	771
Spirit® 210 Original	7,8	8,8	558	640
Spirit® 310 Original	9,4	10,6	672	771
Spirit® 320 Original	12,9	14,7	922	1070
Spirit® 210 Premium	7,8	8,8	558	640
Spirit® 310 Premium	9,4	10,6	672	771
Spirit® 320 Premium	12,9	14,7	922	1070

VALVE ORIFICE SIZE					
MAIN BURNER VALVES					
	LPG Gas			Methane Gas	
	I ₃ B/P - 30 mbar	I ₃₊ - 28-30 / 37 mbar	I ₃ B/P - 50 mbar	G (20)	G (25)
Spirit® 2 Burner	0.99 mm	0.97 mm	0.90 mm	1.40 mm	1.50 mm
Spirit® 3 Burner	0.90 mm	0.86 mm	0.79 mm	1.25 mm	1.35 mm
SIDE BURNER VALVE					
	LPG Gas			Methane Gas	
	I ₃ B/P - 30 mbar	I ₃₊ - 28-30 / 37 mbar	I ₃ B/P - 50 mbar	G (20)	G (25)
Spirit® 320	0.98 mm	0.90 mm	0.84 mm	1.39 mm	1.50 mm

REPLACEMENT HOSE, REGULATOR AND VALVE ASSEMBLY

⚠ IMPORTANT NOTICE: We recommend that you replace the gas hose assembly on your Weber® gas grill every five years. Some countries may have requirements that the gas hose be replaced within less than five years, in which case that country's requirement would take precedence.

For replacement hose, regulator, and valve assemblies, contact the Customer Service Representative in your area using the contact information on our web site. Log on to www.weber.com®.

LPG CYLINDER INSTALLATION INSIDE CABINET

WHERE DOES THE LPG CYLINDER GO?

The type and size of cylinder you purchase will determine if the cylinder can be located inside or outside the base cabinet. There are two location options: inside the cabinet within the cylinder brackets, or outside the cabinet on the ground.

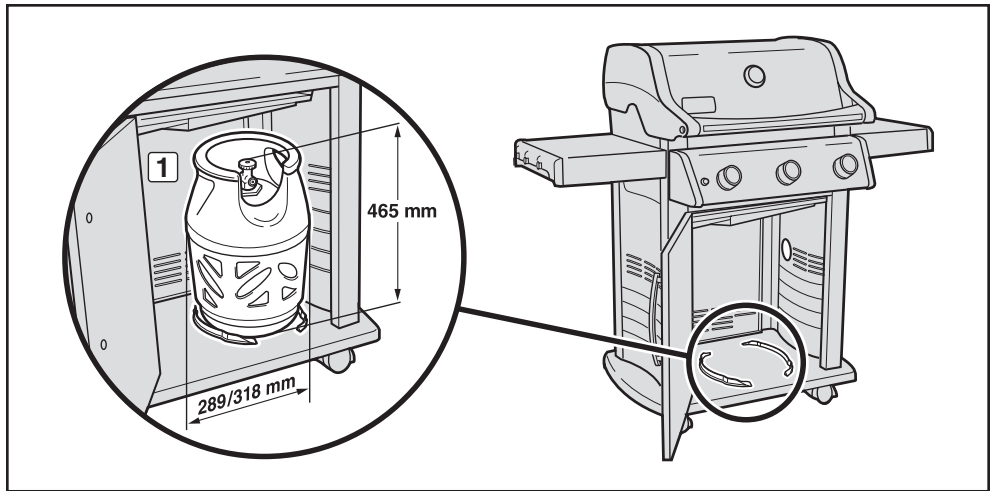

INSIDE CABINET REQUIREMENTS

The LPG cylinder can be placed inside the grill cabinet if the cylinder does not exceed the maximum size requirements. The maximum size requirements for cylinders installed inside the cabinet are:

- Cylinder Capacity:** 6 kg maximum
- Cylinder Height:** 465 mm maximum
- Cylinder Width:** 289 mm maximum (rectangular footprint) or 318 mm maximum (round footprint)

Also, the base of the cylinder must fit between the cylinder brackets and rest flat on the bottom panel (1).

⚠ WARNING: If the LPG cylinder does not meet the cylinder size requirements for placing inside the cabinet, do not attempt to place or connect the cylinder inside the cabinet. Place and connect the cylinder outside the cabinet. Failure to do so could cause damage to the hose resulting in a fire or explosion, which can cause serious bodily injury or death, and damage to property.

Several possible cylinder models approved for installation inside the cabinet are illustrated, with dimensions included.

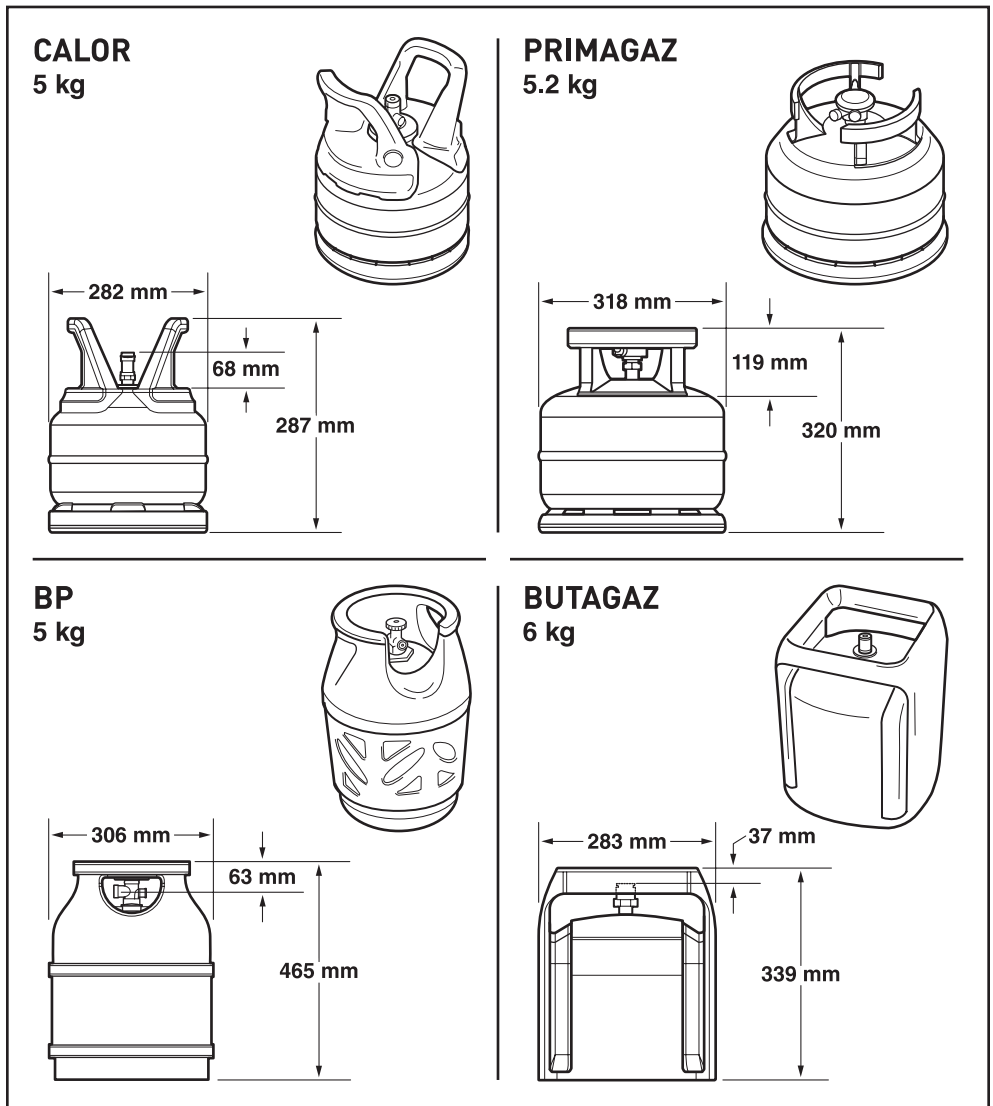

**Maximum LPG cylinder capacity INSIDE cabinet is 6 kg.
The length of hose must not exceed 1.5 metres.**

LPG CYLINDER INSTALLATION INSIDE CABINET

INSIDE CABINET INSTALLATION

You will need: cylinder brackets (1).

- A) Open the grill cabinet. The cylinder brackets snap into the mounting holes in the bottom panel as shown in the illustration (2). Insert cylinder bracket tabs into rectangular slots. Secure brackets in place by pivoting them down to lock centre tab in place.
- B) Lift and place the cylinder between the cylinder brackets (3) on the bottom panel. The base of the cylinder must fit between the cylinder brackets (4).
- C) Turn the cylinder so the valve opening faces the front of the grill.
- D) Connect the regulator to the LPG cylinder. Refer to "CONNECTING THE REGULATOR."

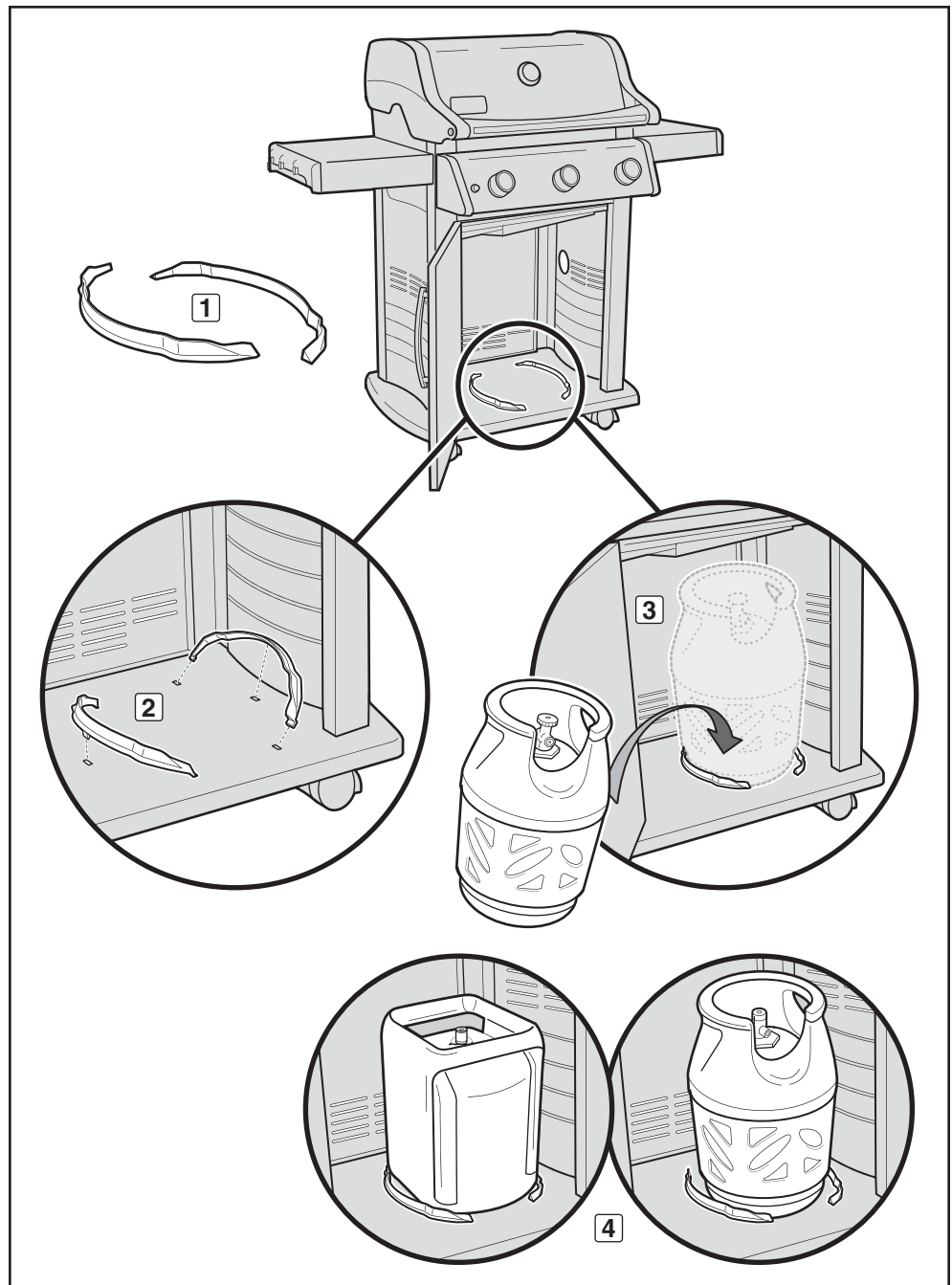

LPG CYLINDER INSTALLATION OUTSIDE CABINET

OUTSIDE CABINET REQUIREMENTS

If the cylinder you have does not meet the size requirements for placement inside the cabinet, the cylinder must be placed on the ground outside and to the right of the cabinet. The maximum size requirements for cylinders installed outside the cabinet are:

- Cylinder Capacity:** 13 kg maximum
Cylinder Height: 587 mm maximum
Cylinder Width: 306 mm maximum

GROUND PLACEMENT INSTALLATION

- Pass the regulator hose (1) out through the side panel opening.
- Place the cylinder on the ground, outside the cabinet, on the right side of the grill.
- Turn the LPG cylinder so the opening of the valve is facing forward.
- Connect the regulator to the LPG cylinder. Refer to "CONNECTING THE REGULATOR."

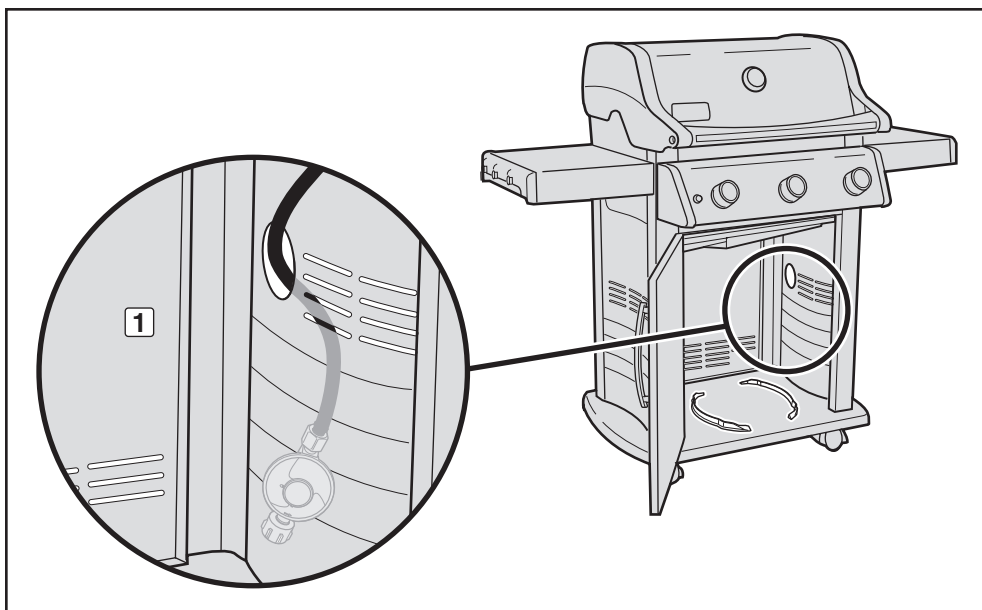

Maximum LPG cylinder capacity OUTSIDE cabinet is 13 kg.

The length of hose must not exceed 1.5 metres.

WHAT IS A REGULATOR?

Your Weber® gas grill is equipped with a pressure regulator, which is a device to control and maintain uniform gas pressure as gas is released from the LPG cylinder.

CONNECTING THE REGULATOR TO THE CYLINDER

A) Connect regulator to LPG cylinder.

⚠ WARNING: Make sure that the LPG cylinder or regulator valve is closed.

Some regulators push ON to connect and pull OFF to disconnect; others have a nut with a left-hand thread that connects to the cylinder valve. Identify your regulator type and follow one of the connection instructions specific to that regulator.

Connect by Turning Clockwise

Screw regulator onto cylinder by turning fitting clockwise (1). Position the regulator so that the vent hole (2) faces down.

Connect by Turning Anti-Clockwise

Screw regulator onto cylinder by turning fitting anti-clockwise (3) (4).

Connect by Turning Lever/Snapping into Position

Turn regulator lever (5) to the down/off position. Push regulator down on cylinder valve until regulator snaps into position (6).

Connect by Sliding Collar

Make sure regulator lever is in the off position (7) (10). Slide the collar of the regulator up (8) (11). Push the regulator down onto the cylinder valve and maintain pressure. Slide collar down to close (9) (12). If regulator does not lock, repeat procedure.

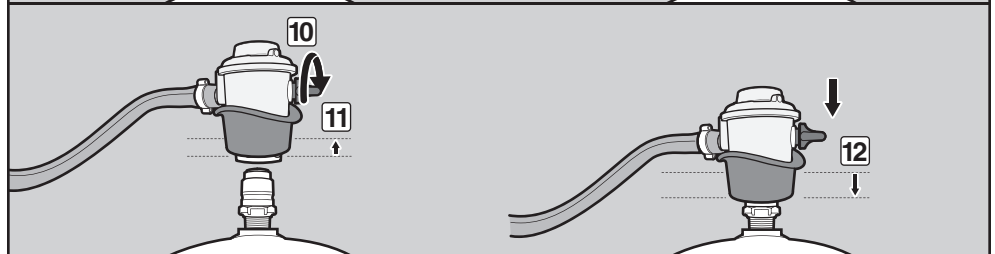
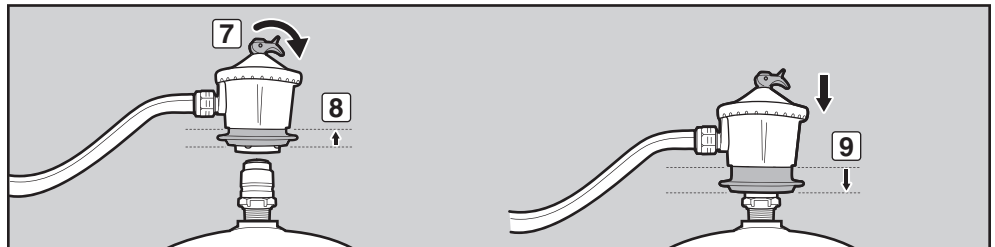
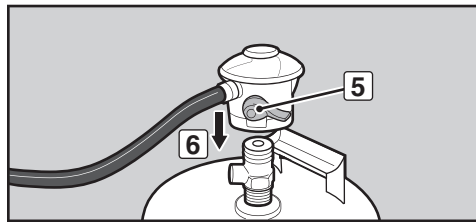
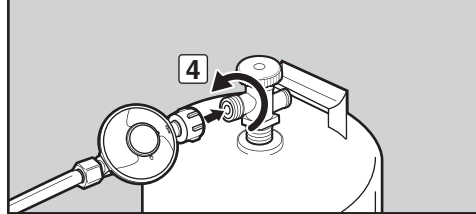
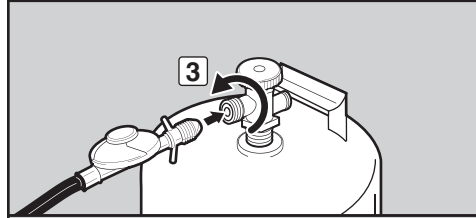
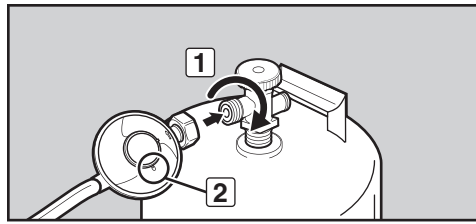

WHAT IS A LEAK CHECK?

The fuel system in your grill features many connections and fittings. A leak check is a reliable way to make sure that no gas is escaping from any of the connections or fittings.

Although all factory-made connections have been thoroughly checked for gas leaks, it's important to perform a leak check before using your grill for the first time, as well as anytime you disconnect and reconnect a fitting and each time you perform routine maintenance.

Safety must be considered when you are deciding where to place and operate your grill. Be sure to read the following warnings before installing or using your grill.

WARNINGS:

- ⚠ This appliance is intended for outdoor use only and should never be used in garages and roofed or enclosed porches or verandas.
- ⚠ Your Weber® gas grill must never be used under an unprotected combustible roof or overhang.
- ⚠ Your Weber® gas grill is not intended to be installed in or on caravans and/or boats.
- ⚠ Flammable materials should not be present within approximately 60 cm of the grill. This includes the top, bottom, back or sides of the grill.
- ⚠ Keep the cooking area clear of flammable vapours and liquids such as petrol, alcohol, etc., and combustible materials.
- ⚠ Keep ventilation openings for cylinder enclosure free and clear from debris.
- ⚠ This appliance gets very hot. Take special care when children or elderly people are present.
- ⚠ Do not move the appliance when it is alight.

PARTIAL DISASSEMBLY OF YOUR GRILL FOR A LEAK CHECK

In order to perform the leak check, you need to have access to the gas valves, which will require some simple grill disassembly.

Confirm that Grill is Off

- A) Turn gas supply off at source.
- B) Check that **ALL** burner control knobs are in the off (○) position (1). Control knobs are shipped in the off (○) position, but you should check to be sure that they are turned off. Check by pushing control knobs in and turning them clockwise. If they do not turn, they are off. If they do turn, continue turning them clockwise until they stop; then they are off. If your grill has a side burner, make sure the side burner control knob is turned off.

Remove Control Panel

You will need: A Phillips screwdriver.

- A) Disconnect the two wires from the igniter button located on the underside of the control panel (2). *NOTE: Pull from terminals at ends of wires.*
- B) Remove control knobs (3).
- C) Remove the screws from the front of the control panel with a Phillips screwdriver (4).
- D) Carefully lift control panel up and then pull forward away from frame (5).

Your grill is now ready for a leak check. Proceed to "CHECKING FOR GAS LEAKS."

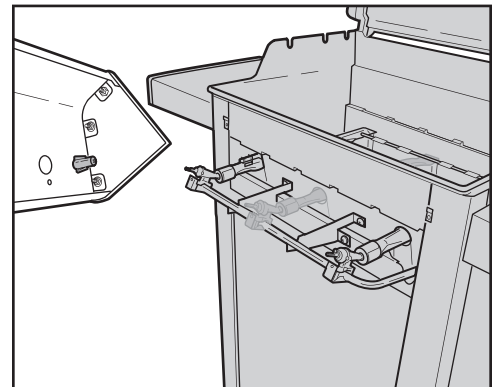
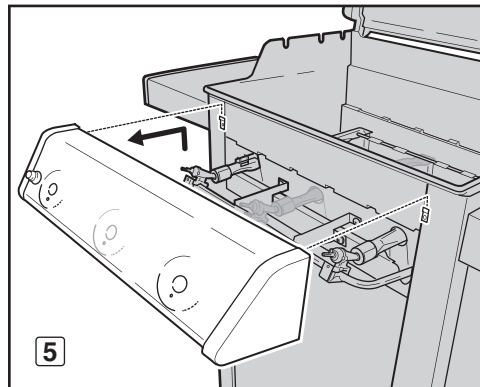
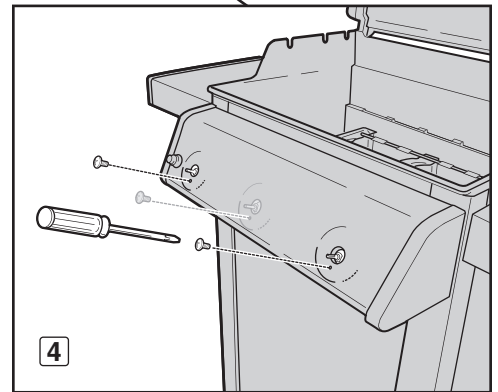
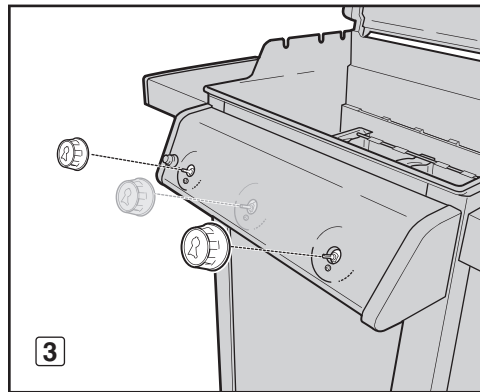
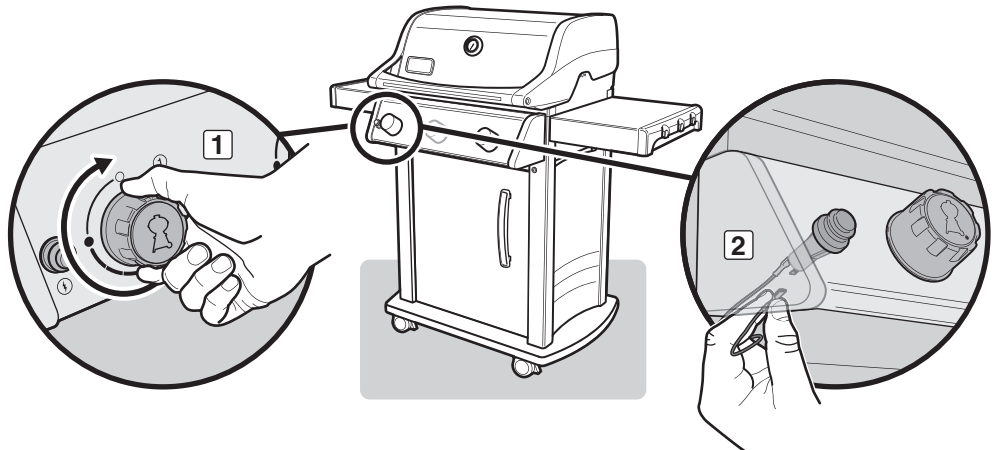

PREPARING TO USE YOUR GRILL

⚠ DANGER

Do not use an open flame to check for gas leaks. Be sure there are no sparks or open flames in the area while you check for leaks. Sparks or open flames will result in a fire or explosion, which can cause serious bodily injury or death and damage to property.

⚠ **WARNING:** The gas connections of your gas grill have been factory-tested. We do, however, recommend that you leak-check all gas connections before operating your gas grill.

⚠ **WARNING:** Perform these leak checks even if your grill was dealer- or store-assembled.

⚠ **WARNING:** You should check for gas leaks every time you disconnect and reconnect a gas fitting.

NOTE: All factory-made connections have been thoroughly checked for gas leaks and the burners have been flame-tested. As a safety precaution, however, you should check all fittings for leaks before using your Weber® gas grill. Shipping and handling may loosen or damage a gas fitting.

CHECKING FOR GAS LEAKS

You will need: A spray bottle or brush or rag and a soap-and-water solution. (You can make your own soap-and-water solution by mixing 20% liquid soap with 80% water; or, you can purchase solution in the plumbing section of any hardware store.)

A) Turn gas supply on at source.

⚠ **WARNING:** Do not ignite burners when leak-checking

Identify your regulator type. Follow the instructions for that regulator.

Turn Valve

Turn cylinder valve anti-clockwise (1) (2) (3).

Move Lever

Move regulator lever to the on position (4) (5) (6).

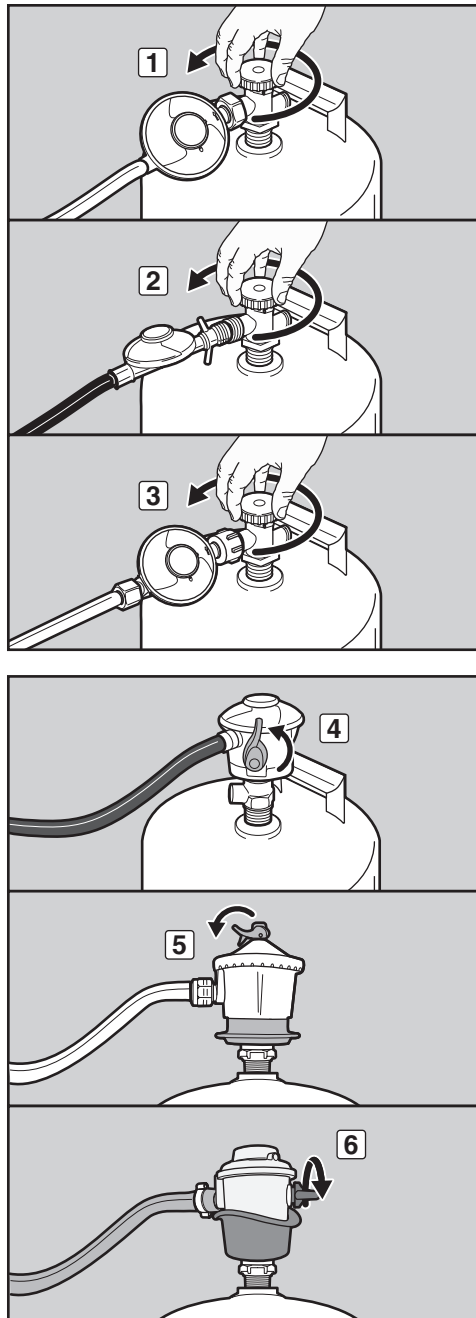

PREPARING TO USE YOUR GRILL

CHECKING FOR GAS LEAKS (continued)

B) To check for leaks, wet fittings with the soap-and-water solution, using a spray bottle, brush or rag. If bubbles form, or if a bubble grows, there is a leak. Apply the soap-and-water solution, to the following connections:

- a) Regulator hose-to-bulkhead connection (1).
- b) Corrugated manifold hose-to-bulkhead connection (2).
- c) Corrugated manifold hose-to-manifold connection (3).

For Spirit® grills with side burners (320 models):

- d) Side burner hose-to-manifold connection (4).
- e) Side burner hose-to-valve connection (5).

⚠ **WARNING: If there is a leak at connections (1, 2, 3, 4 or 5), turn off the gas, tighten the fitting with a spanner, and recheck for leaks with soap-and-water solution. If a leak persists after tightening the fitting, turn off the gas. DO NOT OPERATE THE GRILL. Contact the Customer Service Representative in your area using the contact information on our web site. Log onto www.weber.com®.**

- f) Regulator-to-cylinder connection (6).
- g) Regulator hose-to-regulator connection (7).
- h) Valves-to-manifold connections (8).

⚠ **WARNING: If there is a leak at connections (6, 7, or 8), turn off the gas. DO NOT OPERATE THE GRILL. Contact the Customer Service Representative in your area using the contact information on our web site. Log onto www.weber.com®.**

C) When leak checking is complete, turn gas supply off at the source and rinse connections with water.

NOTE: Since some leak test solutions, including soap and water, may be slightly corrosive, all connections should be rinsed with water after checking for leaks.

Reinstall Control Panel

You will need: A Phillips screwdriver.

- A) Align valve stems with holes in control panel. Position top edge of control panel on tabs of frame assembly. Push control panel down into position.
- B) Fasten control panel with screws.
- C) Place control knobs onto valve stems.
- D) Connect the wires to the igniter button.

⚠ **WARNING: Make sure that all parts are assembled and hardware is fully tightened before operating the grill. Your actions, if you fail to follow this product warning, may cause a fire, an explosion, or structural failure resulting in serious personal injury or death as well as damage to property.**

Now you are ready to use your grill.

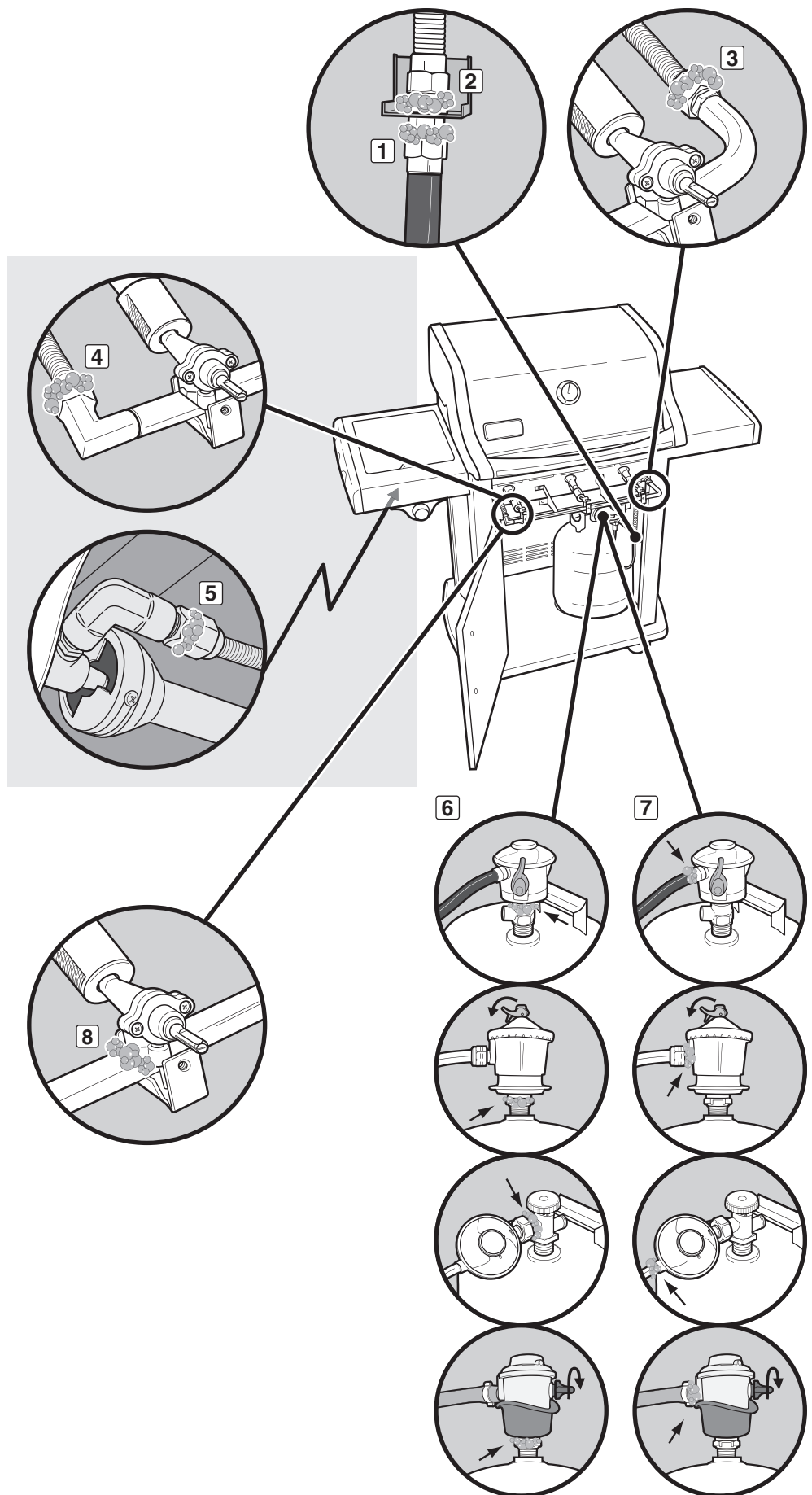

PREPARING TO USE YOUR GRILL

DISCONNECTING THE REGULATOR

A) Remove the gas supply cylinder by shutting off the gas supply and disconnecting the hose and regulator assembly from the cylinder.

⚠ WARNING: Make sure that the LPG cylinder or regulator valve is closed.

Identify your regulator type. Follow the disconnection instructions for that regulator.

Disconnect by Turning Anti-Clockwise

Unscrew regulator from cylinder by turning fitting anti-clockwise (1).

Disconnect by Turning Clockwise

Unscrew regulator from cylinder by turning fitting clockwise (2) (3).

Disconnect by Turning Lever

Turn regulator lever to the down/off position (4). Push in on regulator lever (5) until it releases from the cylinder (6).

Disconnect by Sliding Collar

Make sure regulator lever is in the off position (7) (9). Slide the collar of the regulator up (8) (10) to disconnect from the cylinder.

B) Exchange empty cylinder for a full cylinder.

REFILLING THE LPG CYLINDER

We recommend that you refill the LP cylinder before it is completely empty. To refill, take LP cylinder to a "Gas Propane" dealer.

RECONNECT THE LPG CYLINDER

Refer to "CONNECTING THE REGULATOR."

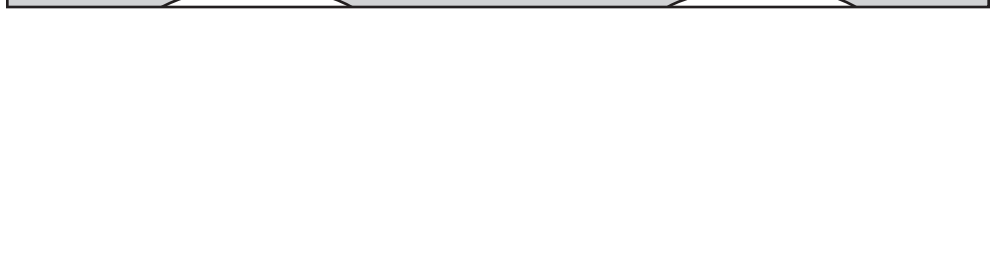
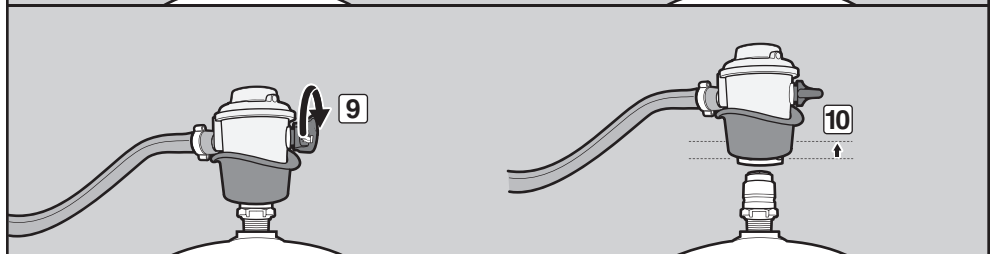
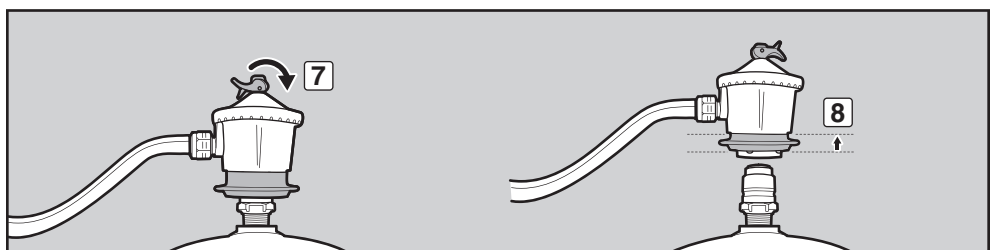
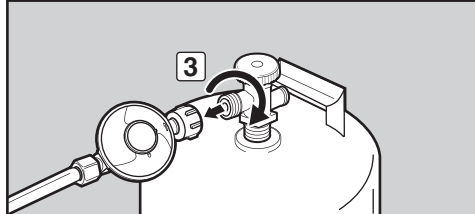
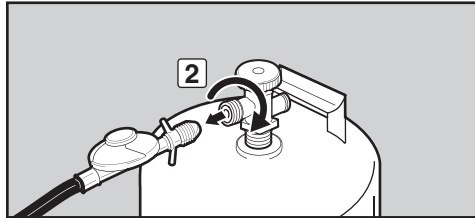
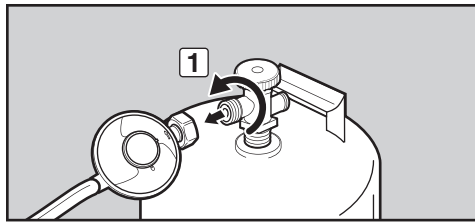

TIPS & HINTS

- Always preheat the grill before cooking. Set all burners on high heat and close lid; preheat for 10 minutes, or until thermometer registers 500° – 550°F (260° – 290°C).
- The temperature of your gas grill may run hotter than normal for the first few uses.
- Recipe grilling times are based on outside temperatures of 70°F (20°C) and little or no wind. Allow for more cooking time on cold or windy days, or at higher altitudes. Allow for less cooking time in extremely hot weather.
- Grilling conditions may require adjustment of the burner controls to attain the correct cooking temperatures.
- Sear meats and cook with the lid down for perfectly grilled food every time.
- Crowding food onto a cooking grate means more time will be required to cook the food.
- Trim excess fat from steaks, chops, and roasts, leaving no more than a scant ¼ inch (6.4 mm) of fat. Less fat makes cleanup easier, and is a virtual guarantee against unwanted flare-ups.
- In general, large pieces of meat will require more cooking time per pound than small pieces of meat.
- Some foods, such as a casserole or thin fish fillets, will require a container for grilling. Disposable foil pans are very convenient, but any metal pan with ovenproof handles can also be used.
- Foods in containers, such as baked beans, will require more time if grilled in a deep casserole than in a shallow baking pan.
- Foods placed on the cooking grate directly above burners may require turning or moving to a less hot area.
- Use tongs rather than a fork for turning and handling meats to avoid losing natural juices. Use two spatulas for handling large whole fish.
- Always be sure the slide-out grease tray and catch pan are clean and free from debris.
- Do not line the slide-out grease tray with foil. This could prevent the grease from flowing into the catch pan.
- If an unwanted flare-up should occur, turn all burners off and move food to another area of the cooking grate. Any flames will quickly subside. After flames subside, relight the grill. **NEVER USE WATER TO EXTINGUISH FLAMES ON A GAS GRILL.**
- Using a timer will help to alert you when “well done” is about to become “overdone.”

PREHEATING

Preheating the grill before grilling is important. To preheat: Light your grill according to the instructions in the Owner's Guide; then turn all burners to start/high (†) position, close the lid, and preheat until the temperature reaches between 500° and 550°F (260° and 290°C), the recommended broiling temperature. This will take 10 to 15 minutes depending on conditions such as air temperature and wind. After preheating, you can adjust the individual burners as desired.

⚠ WARNING: Should the burners go out while grill is in operation, turn all gas valves off. Open the lid and wait five minutes before attempting to relight grill, using the igniting instructions.

COVERED COOKING

All grilling is done with the lid down to provide uniform, evenly circulated heat. With the lid closed, the gas grill cooks much like a convection oven. The thermometer in the lid indicates the cooking temperature inside the grill. All preheating and grilling is done with the lid down. No peeking — heat is lost every time you lift the lid.

FLAVORIZER® SYSTEM

The closed lid and Flavorizer® bars produce that “outdoor” flavour in the food. When meat juices drip from the food onto the specially angled Flavorizer® bars, they create smoke that gives foods an irresistible barbecued flavour. Thanks to the unique design of the burners, the Flavorizer® bars, and the flexible temperature controls, uncontrolled flare-ups are virtually eliminated, because YOU control the flames.

DRIPPINGS AND GREASE

Because of the special design of the Flavorizer® bars and burners, excess fats are directed down the slide-out grease tray and into the catch pan. Disposable drip pans that fit the catch pan are available.

SAFETY CHECKS BEFORE USING YOUR GRILL

SAFETY FIRST

It's sensible and smart to get into the habit of performing a few safety checks before grilling.

When you are getting ready to grill, your first thought should always be safety. Set out below are a few safety checks that you should perform each time you grill.

SLIDE-OUT GREASE TRAY

Your grill was built with a grease collection system, which funnels grease away from food and into removable containers.

Check the slide-out grease tray for grease build-up each time you use your grill. Remove excess grease with a plastic scraper (1). Wash the grease tray with a soap-and-water solution and rinse with water.

⚠ CAUTION: Do not line the slide-out grease tray with aluminium foil.

CATCH PAN AND DISPOSABLE DRIP PAN

Grease from the slide-out grease tray funnels into a catch pan. Cleaning the catch pan is just as important as cleaning the slide-out grease tray.

Check the catch pan for grease build-up each time you use your grill. Remove excess grease with a plastic scraper (2). Wash the catch pan with warm, soapy water and rinse with water. To keep the catch pan cleaner longer, you can line the catch pan with a Weber® disposable drip pan or with aluminium foil.

⚠ WARNING: Check the slide-out grease tray and catch pan for grease build-up each time before using. Remove excess grease to avoid a grease fire. A grease fire can cause serious bodily injury or damage to property.

HOSE INSPECTION

The hose should be inspected routinely for any signs of cracking (3).

⚠ WARNING: Check hose each time before using grill for nicks, cracking, abrasions or cuts. If the hose is found to be damaged in any way, do not use the grill. Replace using only Weber® authorised replacement hose. Contact the Customer Service Representative in your area using the contact information on our web site. Log onto www.weber.com®.

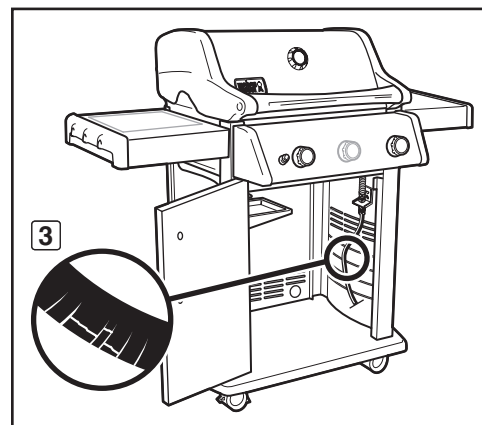
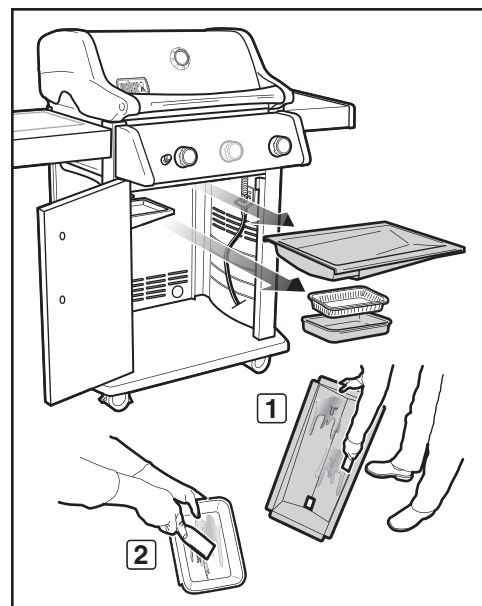

METHODS OF BURNER IGNITION

There are two ways to ignite burner 1. The first is by using the electronic Crossover® ignition system built into your grill. The second is with a match.

Next are the steps for igniting your grill using the electronic Crossover® ignition system. The following page sets out steps for igniting your grill with a match.

MAIN BURNER IGNITION

Electronic Crossover® Ignition System

The electronic Crossover® ignition system ignites burner 1 with a spark from the igniter electrode inside the Gas Catcher™ ignition chamber. You generate the energy for the spark by pushing the igniter button. You will hear the igniter clicking. Burner(s) 2 (and 3) can be lit after burner 1 is lit.

A) Open the grill lid (1).

⚠ DANGER

Failure to open the lid before igniting the grill's burners, or not waiting five minutes to allow the gas to clear if the grill does not light, may result in an explosive flare-up, which can cause serious bodily injury or death.

B) Make sure **ALL** burner control knobs are turned off (2). Check by pushing control knobs in and turning them clockwise until they stop.

⚠ **WARNING: The burner control knobs must be in the off (○) position before you turn on the LPG cylinder valve.**

C) Turn on the cylinder valve using one of the appropriate options based on your cylinder and regulator type. Refer to "A" in "CHECKING FOR GAS LEAKS."

D) Push burner 1 control knob in and turn it anti-clockwise to start/high (f) position (3). **IMPORTANT: Always ignite burner 1 first. The other burner(s) ignite from burner 1.**

E) Push and hold in the igniter button (4). You will hear the igniter clicking.

F) Check that burner 1 is lit by looking through the cooking grates. You should see a flame.

⚠ **WARNING: Do not lean over the open grill.**

⚠ **WARNING: If burner 1 fails to ignite within five seconds, stop, turn the burner control knob to off and wait five minutes to allow the gas to clear before you try again or light with a match.**

G) After burner 1 is lit, you can turn on burner 2 (and burner 3).

TO EXTINGUISH BURNER

Push each burner control knob in and turn it clockwise to the off (○) position. Turn gas supply off at the source.

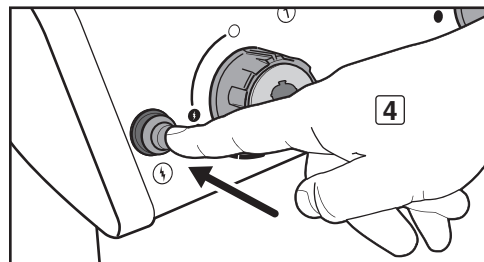
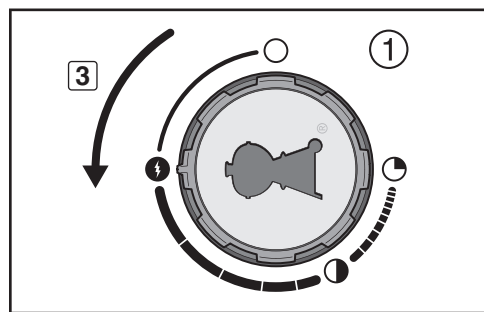
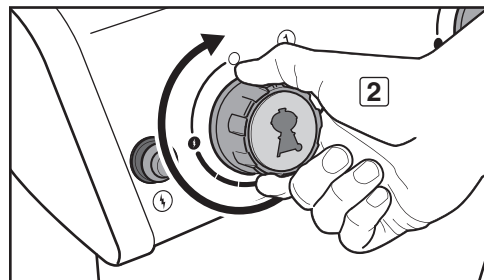
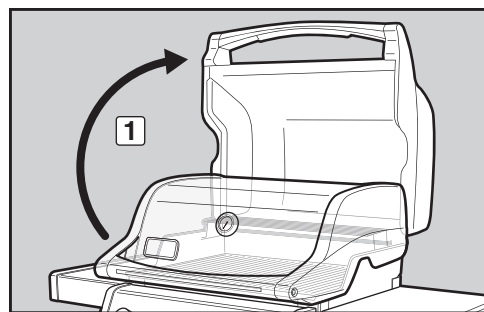

Some batteries have a plastic protective wrap around them. This plastic must be removed before you attempt to ignite your grill with the electronic Crossover® ignition system. Do not confuse this plastic with the battery label.

MAIN BURNER IGNITION & USAGE

MAIN BURNER IGNITION

Lighting with a Match

A) Open the grill lid (1).

⚠ DANGER

Failure to open the lid before igniting the grill's burners, or not waiting five minutes to allow the gas to clear if the grill does not light, may result in an explosive flare-up, which can cause serious bodily injury or death.

B) Make sure **ALL** burner control knobs are turned off (2). Check by pushing control knobs in and turning them clockwise until they stop.

⚠ WARNING: The burner control knobs must be in the off (○) position before you turn on the LPG cylinder valve.

C) Turn on the cylinder valve using one of the appropriate options based on your cylinder and regulator type. Refer to "A)" in "CHECKING FOR GAS LEAKS."

D) Put match in the matchstick holder and strike match. Insert matchstick holder with lit match down through the cooking grates, past the Flavorizer® bars and next to burner 1 (3).

E) Push burner 1 control knob in and turn it anti-clockwise to start/high (†) position (4).

IMPORTANT: Always ignite burner 1 first. The other burner(s) ignite from burner 1.

F) Check that burner 1 is lit by looking through the cooking grates. You should see a flame.

⚠ WARNING: Do not lean over the open grill.

⚠ WARNING: If burner 1 fails to ignite within five seconds, stop, turn the burner control knob to off and wait five minutes to allow the gas to clear before you try again.

G) After burner 1 is lit, you can turn on burner 2 (and burner 3).

TO EXTINGUISH BURNER

Push each burner control knob in and turn it clockwise to the off (○) position. Turn gas supply off at the source.

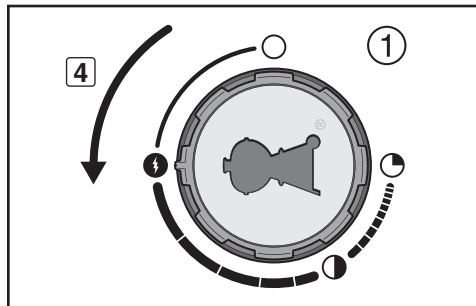
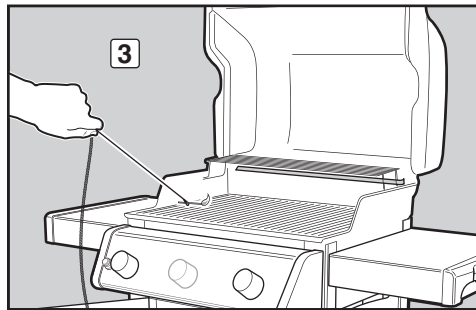
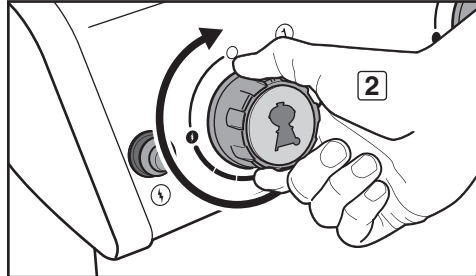
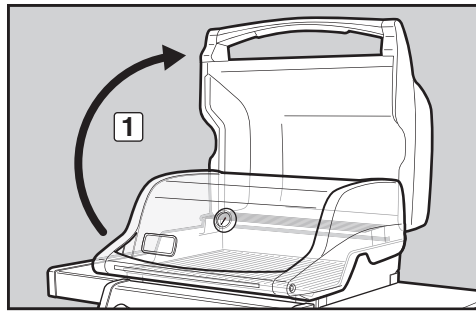

SIDE BURNER IGNITION & USAGE (320 MODELS)

ON THE SIDE...

To maximise your cooking space and to help you multitask, your grill was designed with a side burner. Igniting the side burner is easy. It uses the same igniter button as the main burners, but it ignites independently.

SIDE BURNER IGNITION

Lighting with the Igniter Button

Unlike the main burners, the side burner does not ignite from burner 1. Below are the steps that apply to igniting the side burner using the igniter button.

- A) Open the side burner lid (1).

⚠ DANGER

Failure to open the lid before igniting the side burner, or not waiting five minutes to allow the gas to clear if the side burner does not light, may result in an explosive flare-up, which can cause serious bodily injury or death.

- B) Check that the side burner valve is turned off by pushing side burner control knob in and turning it clockwise until it stops (2). Turn all burners not being used to the off (O) position by pushing all control knobs in and turning them clockwise until they stop.
- C) If it is not already on, turn on the cylinder valve using one of the appropriate options based on your cylinder and regulator type. Refer to "A" in "CHECKING FOR GAS LEAKS."
- D) Push in and turn side burner control knob anti-clockwise to start/high (H) position (3).
- E) Push and hold in the igniter button (4). You will hear the igniter clicking. You should see a flame.

⚠ CAUTION: Side burner flame may be difficult to see on a bright, sunny day.

⚠ WARNING: If the side burner does not light in five seconds:

- Turn off the side burner and main burner control knobs and gas supply at source.
- Wait five minutes to let the gas clear before you try again or try lighting with a match (refer to "Lighting with a Match").

TO EXTINGUISH SIDE BURNER

Push side burner control knob in and turn it clockwise to the off (O) position. Be sure the side burner is off and cool before closing the side burner lid.

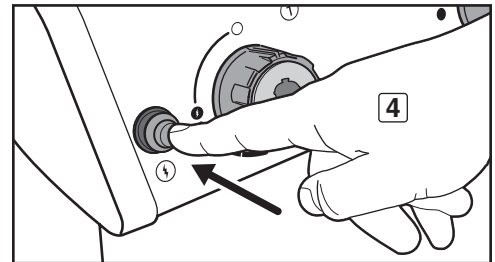
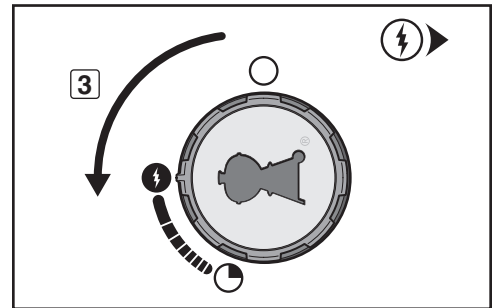
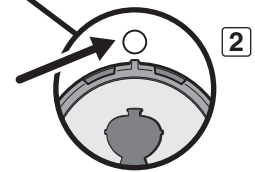
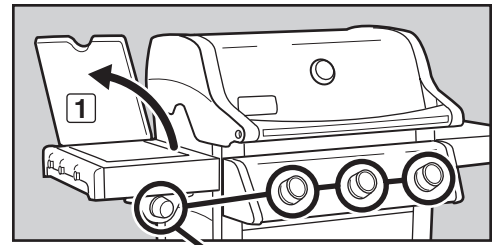

SIDE BURNER IGNITION & USAGE (320 MODELS)

SIDE BURNER IGNITION

Lighting with a Match

A) Open the side burner lid (1).

⚠ DANGER

Failure to open the lid before igniting the side burner, or not waiting five minutes to allow the gas to clear if the side burner does not light, may result in an explosive flare-up, which can cause serious bodily injury or death.

B) Check that the side burner valve is turned off by pushing side burner control knob in and turning it clockwise until it stops (2). Turn all burners not being used to the off (○) position by pushing all control knobs in and turning them clockwise until they stop.

C) If it is not already on, turn on the cylinder valve using one of the appropriate options based on your cylinder and regulator type. Refer to "A" in "CHECKING FOR GAS LEAKS."

D) Put match in the matchstick holder and strike match. Place matchstick holder with lit match close to side burner (3).

E) Push in and turn side burner control knob anti-clockwise to start/high (†) position (4). You should see a flame.

⚠ CAUTION: Side burner flame may be difficult to see on a bright, sunny day.

⚠ WARNING: If the side burner does not light in five seconds:

a) Turn off the side burner and main burner control knobs and gas supply at source.

b) Wait five minutes to let the gas clear before you try again.

TO EXTINGUISH SIDE BURNER

Push side burner control knob in and turn it clockwise to the off (○) position. Be sure the side burner is off and cool before closing the side burner lid.

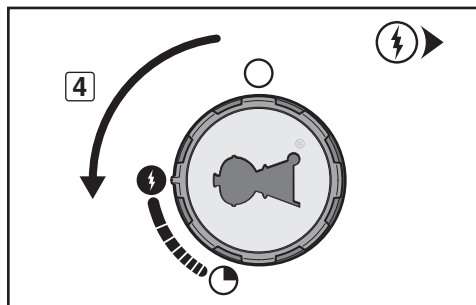
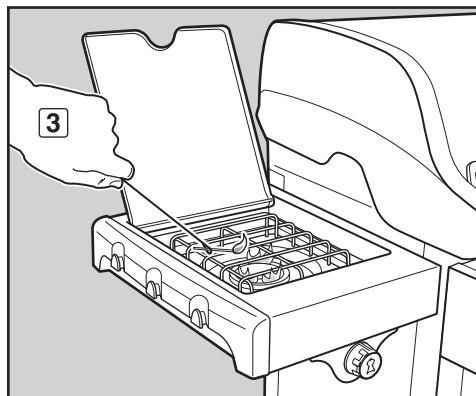
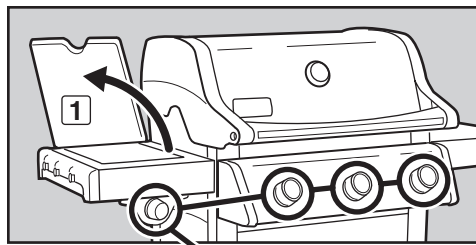

TROUBLESHOOTING

GENERAL TROUBLESHOOTING

PROBLEMS	SOLUTIONS
Burner does not ignite when you push the igniter button.	<ul style="list-style-type: none"> Be sure that there is gas flow to the burners by attempting to match-light your burners. Refer to “MAIN BURNER IGNITION—Lighting with a Match.” If match-lighting is successful, the problem lies in the ignition system. Refer to “MAINTAINING THE ELECTRONIC CROSSOVER® IGNITION SYSTEM.” Be sure that wires are correctly inserted into terminals on igniter module. Check that the wires are connected to terminals on igniter button under the control panel. Refer to “IGNITER MODULE WIRE GUIDE.” If a new battery is installed, confirm that battery’s plastic wrapping has been removed. Verify that the battery is in good condition and has been installed correctly. Refer to “MAINTAINING THE ELECTRONIC CROSSOVER® IGNITION SYSTEM.”
Burners do not ignite. Burners have a small flickering flame when burner control knobs are in the high (H) position. Grill temperature only reaches 250° to 300° F in the high (H) position.	<p><i>Some countries have regulators with an excess gas flow safety device. The excess flow safety device, which is part of the grill-to-cylinder connection, may have been activated. To reset the excess flow safety device, close the LPG cylinder valve and turn all burner control knobs to the off (O) position. Open the grill lid. Wait at least five minutes for the gas to clear before attempting to light the grill. SLOWLY turn the LPG cylinder valve until it is completely open. Wait several seconds; then ignite your grill. Refer to “MAIN BURNER IGNITION & USAGE.”</i></p>
Burner does not ignite, or flame is low when set to high (H) position.	<ul style="list-style-type: none"> LPG fuel could be low or empty. Refill LPG cylinder. Fuel hose could be bent or kinked. Straighten fuel hose.
Burner flame pattern is erratic. Flame is low when burner is set to high (H) position. Flames do not run the whole length of the burner tube.	<ul style="list-style-type: none"> Clean burner ports that run down the entire length of burner tube. Refer to “ANNUAL MAINTENANCE.”
Burners burn with a yellow or orange flame, combined with the smell of gas.	<ul style="list-style-type: none"> Inspect spider/insect screens for possible obstructions. (Blockage of holes.) Clean spider/insect screens. Refer to “ANNUAL MAINTENANCE.”
Experiencing flare-ups.	<ul style="list-style-type: none"> Grill must be preheated with all burners on high for 10 to 15 minutes.
⚠ CAUTION: Do not line the slide-out grease tray with aluminium foil.	<ul style="list-style-type: none"> Clean the cooking grates and Flavorizer® bars thoroughly to remove grease. Refer to “ROUTINE MAINTENANCE.” The slide-out grease tray may be dirty and is not allowing grease to flow into catch pan. Clean slide-out grease tray.
Inside of lid appears to be “peeling.” (Resembles paint peeling.)	<ul style="list-style-type: none"> The inside of the lid is porcelain enamel or stainless steel. It is not painted. It cannot “peel.” What you are seeing is baked-on grease that has turned to carbon and is flaking off. THIS IS NOT A DEFECT. Clean thoroughly. Refer to “ROUTINE MAINTENANCE.”

If problems cannot be corrected by using these methods, please contact the Customer Service Representative in your area using the contact information on our web site. Log onto www.weber.com®.

SIDE BURNER TROUBLESHOOTING (320 MODEL)

PROBLEMS	SOLUTIONS
Side burner does not ignite when you push the igniter button.	<ul style="list-style-type: none"> Be sure that there is gas flow to the burner by attempting to match-light your side burner. Refer to “SIDE BURNER IGNITION—Lighting with a Match.” If match-lighting is successful, the problem lies in the ignition system. Refer to “MAINTAINING THE ELECTRONIC CROSSOVER® IGNITION SYSTEM.” Be sure that wires are correctly inserted into terminals on igniter module. Check that the wires are connected to terminals on igniter button under the control panel. Refer to “IGNITER MODULE WIRE GUIDE.” If a new battery is installed, confirm that battery’s plastic wrapping has been removed. Verify that the battery is in good condition and has been installed correctly. Refer to “MAINTAINING THE ELECTRONIC CROSSOVER® IGNITION SYSTEM.”
Side burner does not ignite.	<ul style="list-style-type: none"> Be sure that gas supply is on. <i>Some countries have regulators with an excess gas flow safety device. The excess flow safety device, which is part of the grill-to-cylinder connection, may have been activated. To reset the excess flow safety device, close the LPG cylinder valve and turn all burner control knobs to the off (O) position. Open the grill lid. Wait at least five minutes for the gas to clear before attempting to light the grill. SLOWLY turn the LPG cylinder valve until it is completely open. Wait several seconds; then ignite your grill. Refer to “MAIN BURNER IGNITION & USAGE.”</i>
Side burner does not ignite, or flame is low when burner is on high (H) position.	<ul style="list-style-type: none"> LPG fuel could be low or empty. Refill LPG cylinder. Fuel hose could be bent or kinked. Straighten fuel hose.

If problems cannot be corrected by using these methods, please contact the Customer Service Representative in your area using the contact information on our web site. Log onto www.weber.com®.

ANNUAL MAINTENANCE

KEEPING YOUR WEBER® GAS GRILL IN TIP-TOP SHAPE

⚠ DANGER

Failure to correct any problems described on this page may result in a fire, which can cause serious bodily injury or death, and cause damage to property.

To keep your Weber® gas grill performing as safely and efficiently as on day one, we strongly recommend that you inspect and clean the spider/insect screens and burner tubes at least once a year. Below is important information about these two areas of the grill that should undergo annual maintenance.

If you observe an incorrect flame pattern or blocked burner ports, proceed to the “BURNER TUBE CLEANING OR REPLACEMENT” instructions on the following pages.

BURNER FLAME PATTERN

The burner tubes in your Weber® gas grill were factory set for the correct air and gas mixture. The correct flame pattern is shown in illustration and described below:

- Burner tube (1)
- Tips occasionally flicker yellow (2)
- Light blue (3)
- Dark blue (4)

Check burner flame pattern. If the flames do not match the above description, it could be an indication that the spider/insect screens have become dirty or blocked.

WEBER® SPIDER/INSECT SCREENS

The combustion air openings of the burner tubes (5) are fitted with stainless steel screens to help prevent spiders and other insects from spinning webs and building nests inside the venturi section (6) of the burner tubes. These nests can obstruct the normal gas flow, and can cause gas to flow back out of the combustion air openings (7). This could result in a fire in and around the burner valves, under the control panel, causing serious damage to your grill.

NOTE: If a spider/insect screen becomes damaged or cannot be cleaned, please contact the Customer Service Representative in your area using the contact information on our web site. Log onto www.weber.com®.

BURNER TUBE PORTS

Over time, from repeated use of the grill, the burner tube ports will become dirty. Blocked and dirty ports can restrict full gas flow. Set out below are ways to determine whether burner tubes are dirty or blocked.

- Gas can be smelled in conjunction with burner flames that appear yellow and lazy
- Grill does not reach desired temperature
- Grill heats unevenly
- One or more of the burners do not ignite

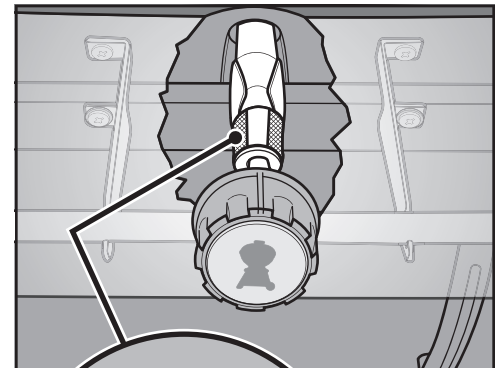
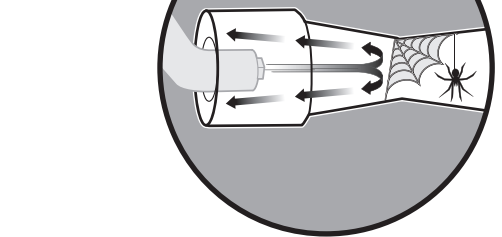
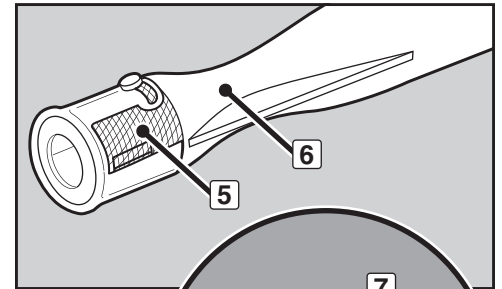
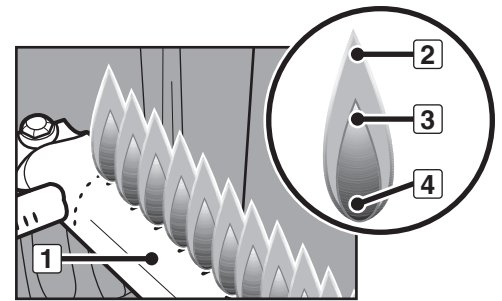

ANNUAL MAINTENANCE

BURNER TUBE CLEANING OR REPLACEMENT

Confirm that Grill is Off

- Turn gas supply off at source and disconnect gas fitting.
- Check that all burner control knobs are in the off (O) position. Check by pushing control knobs in and turning them clockwise until they stop. If they do not turn, they are already off. If they do turn, continue turning them clockwise until they stop; then they are off. If your grill has a side burner, make sure the side burner control knob is turned off.

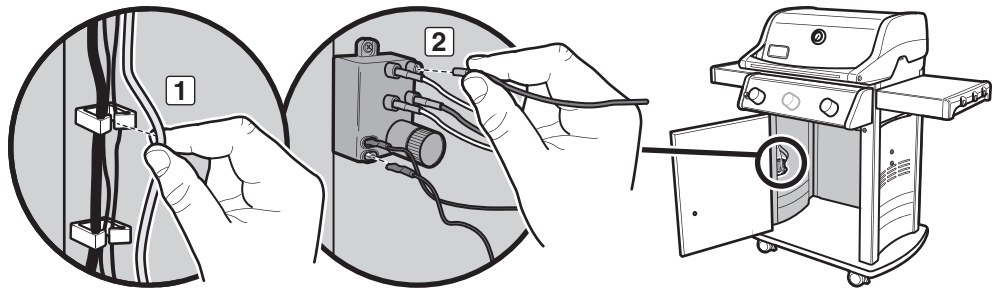

Remove Control Panel

You will need: A Phillips screwdriver.

- Open cabinet door. Remove igniter wires from wire clips on the inside left panel (1). Disconnect wires from igniter module inside the cabinet (2).
NOTE: Do not disconnect by pulling on wires; pull from terminals at ends of wires.
- Remove cookbox components (3).
- Remove control knobs (4).
- Remove screws from the front of the control panel with a Phillips screwdriver (5).
- Carefully lift control panel up and then pull forward and away from cookbox (6).

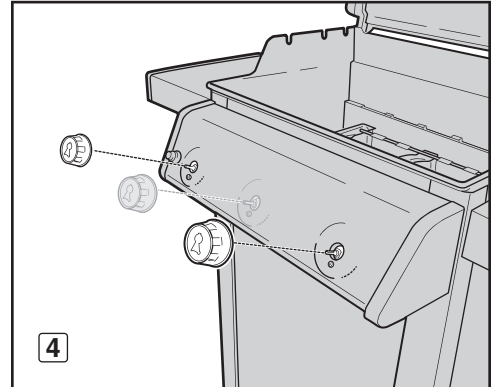
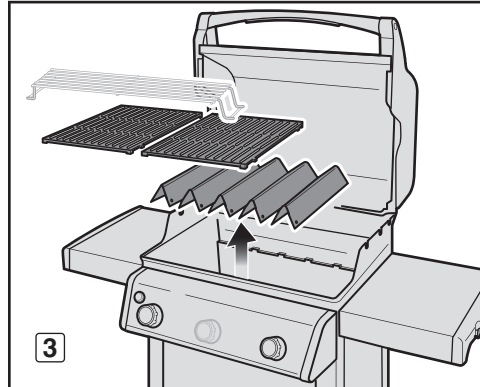

Remove Manifold

You will need: A Phillips screwdriver, two 7/16" spanners.

- With the Phillips screwdriver, remove two screws and two washers attaching manifold to front cross brace (7).
- Using two 7/16" spanners, remove two bolts and two nuts attaching manifold to cookbox (8). Pull manifold forward and away from burner tubes (9). Manifold will remain attached to corrugated gas line(s). Be careful not to let manifold scratch frame or door or kink the attached corrugated gas line(s).

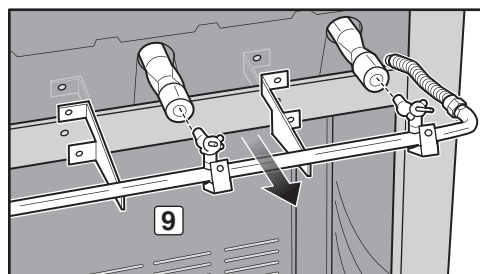
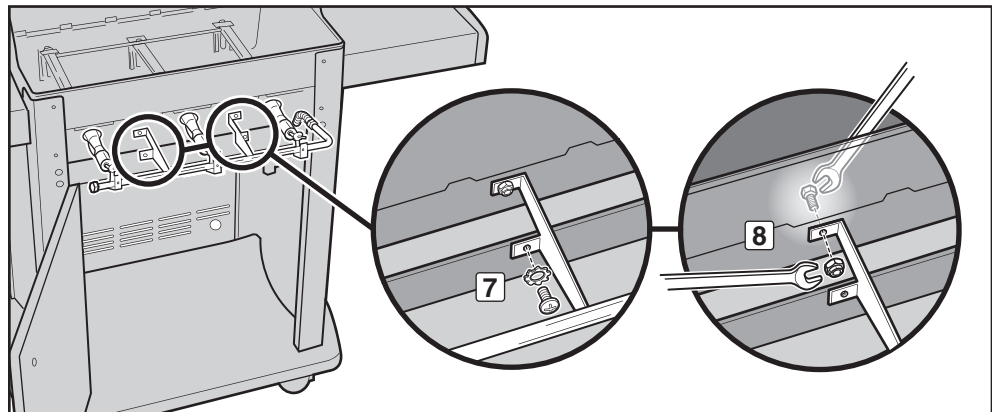
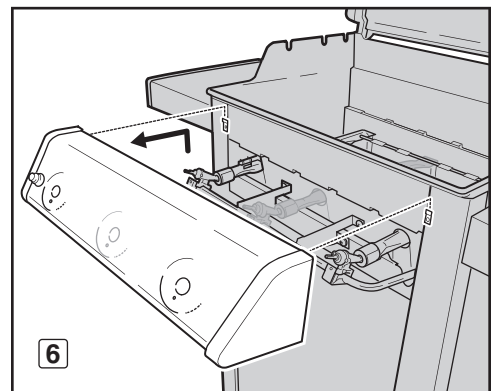
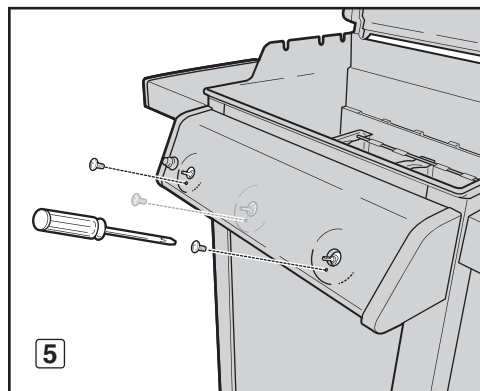

ANNUAL MAINTENANCE

BURNER TUBE CLEANING OR REPLACEMENT (continued)

Remove Burner Tubes

For Spirit® grills with 2 burners (210 model):

- Slide burner tube 1 out from under the guide screw and washer. Move burner tube 1 slightly to the left to detach it from Crossover® tube (1).
- Remove Crossover® tube (2).
- Lift burner tube 1 up and out of cookbox while guiding the wires through the hole in the cookbox (3).
- Slide burner tube 2 out from under the guide screw and washer. Lift burner tube 2 up and out of the cookbox (4).

210/220

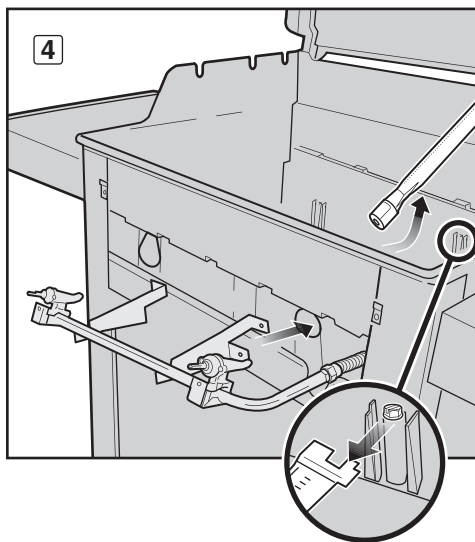
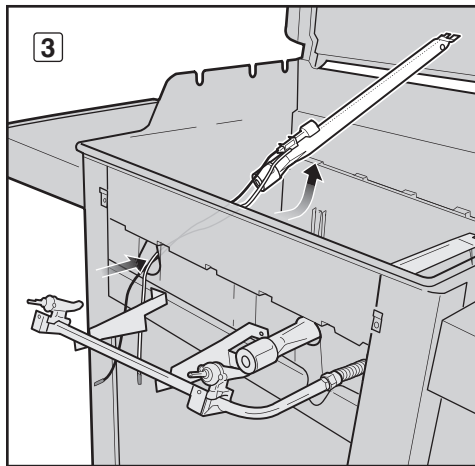
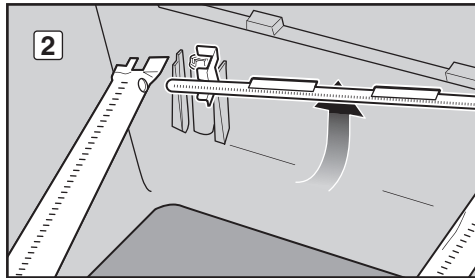
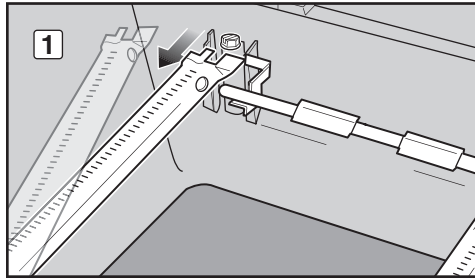

310/320

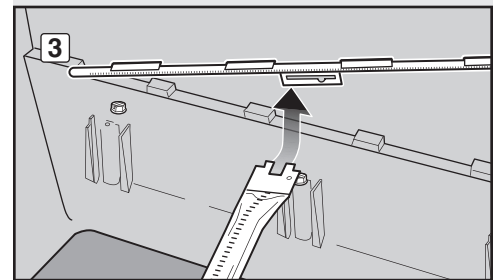
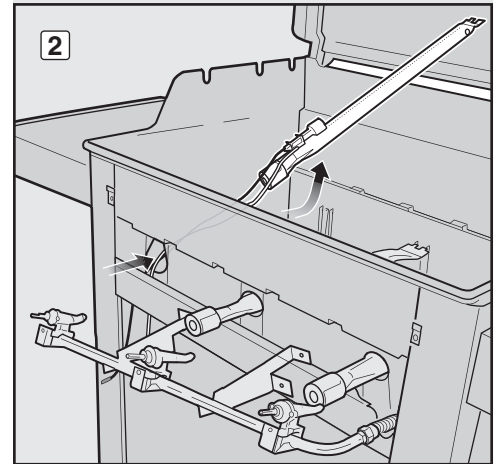
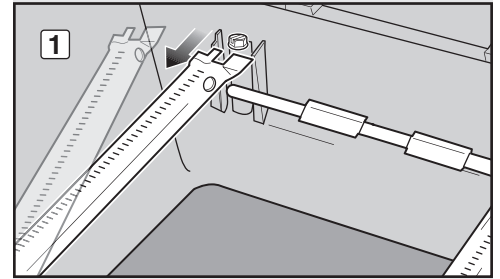

For Spirit® grills with 3 burners (310 and 320 models):

- Slide burner tube 1 out from under the guide screw and washer. Move burner tube 1 slightly to the left to detach it from Crossover® tube (1).
- Lift burner tube 1 up and out of cookbox while guiding the wires through the hole in the cookbox (2).
- Slide burner tube 3 out from under the guide screw and washer. Move burner tube 3 slightly to the right to detach it from Crossover® tube. Lift burner tube 3 up and out of cookbox.
- Slide burner tube 2 out from under the guide screw and washer. Remove the Crossover® tube by moving it toward back of cookbox (3). Lift burner tube 2 up and out of cookbox.

BURNER TUBE CLEANING OR REPLACEMENT (continued)

Clean Burner Tubes

You will need: A torch, a wire (a straightened-out coat hanger), a suitable stainless steel bristle brush, and a soft bristle brush (toothbrush).

- A) Look inside each burner tube and Crossover® tube with a torch (1).
- B) Clean any debris or blockage from the inside of the tubes with the wire (2).
- C) Check spider/insect screens at the ends of the burner tubes and clean them using the soft bristle brush (3).

⚠ **CAUTION: Do not clean the spider/insect screens with hard or sharp tools. Do not dislodge the spider/insect screens or enlarge the screen openings.**

- D) Use the steel bristle brush to clean the outside of the burner tubes and the Crossover® tube. This is done to make sure all burner ports (openings) running along the length of the tubes are fully open. When cleaning burner tube 1, avoid damaging the igniter electrode by carefully brushing around it (4).

⚠ **CAUTION: Do not enlarge the burner ports when cleaning.**

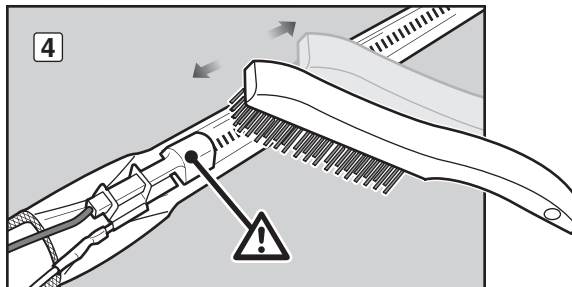
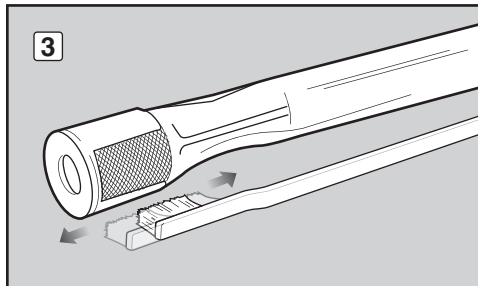
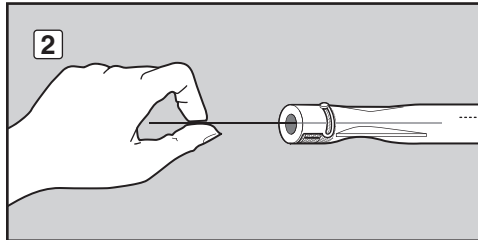
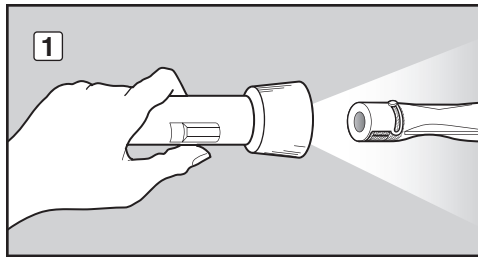

ANNUAL MAINTENANCE

BURNER TUBE CLEANING OR REPLACEMENT (continued)

Reinstall Burner Tubes

For Spirit® grills with 2 burners (210 model):

- A) Put burner tube 2 inside cookbox and pass the front end of tube out through burner tube 2 opening. *Note: Single row of burner ports should be facing up.* Slide burner tube 2 under the guide screw and washer (1).
- B) Put burner tube 1 inside cookbox and pass igniter wires and the front end of tube out through burner tube 1 opening (2). Guide wires from burner tube 1 between front cross brace and cookbox and down into cabinet (3).
- C) While holding burner tube 1, insert left side of Crossover® tube into Crossover® burner hole (4). Guide right side of Crossover® tube into Crossover® burner hole in burner tube 2 (not pictured). *Note: The Crossover® tube burner ports should face the front of the cookbox.*
- D) Slide burner tube 1 under the guide screw and washer (5).

210/220

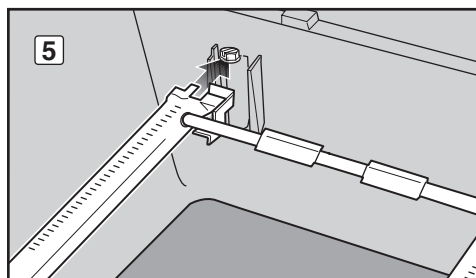
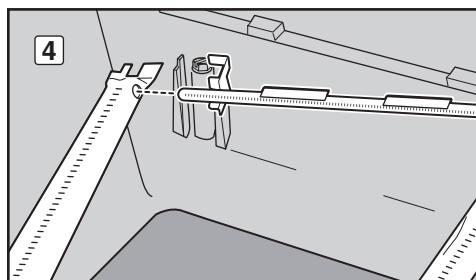
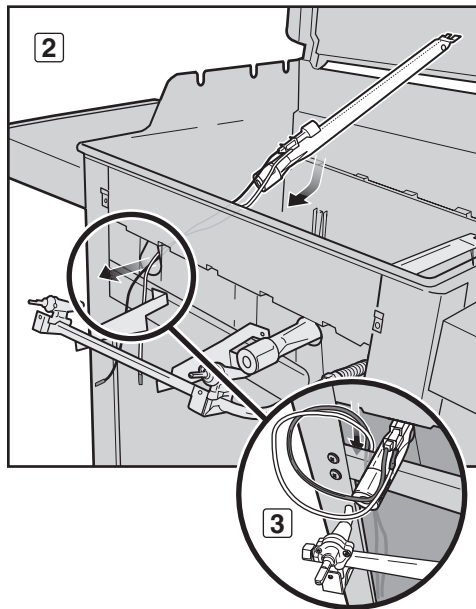
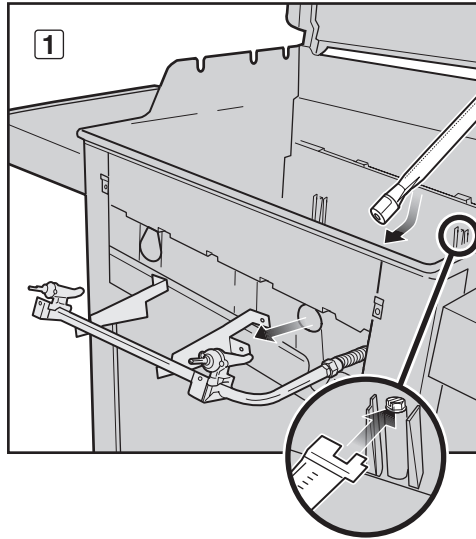

310/320

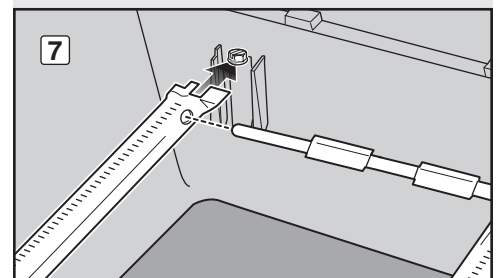
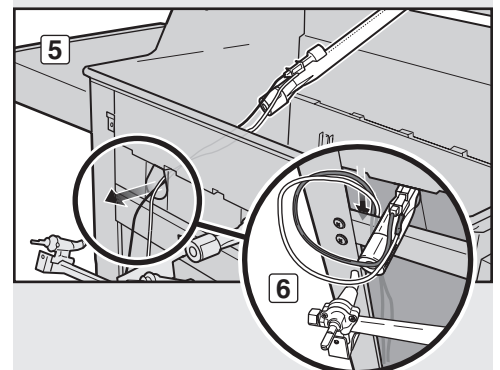
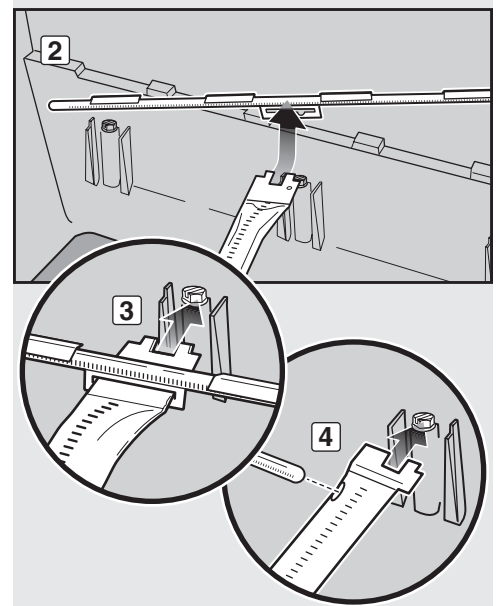
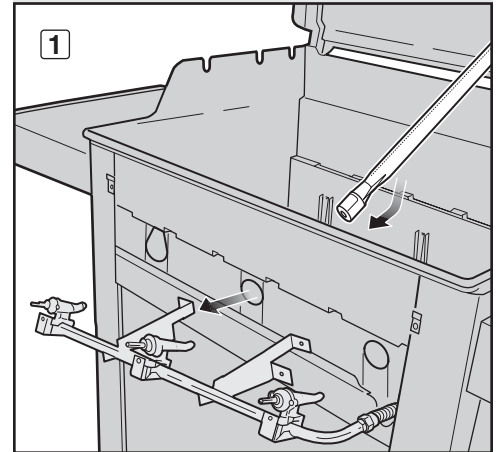

For Spirit® grills with 3 burners (310 and 320 models):

- A) Put burner tube 2 inside cookbox and pass the front end of tube out through burner tube 2 opening (1). *Note: Single row of burner ports should be facing up.*
- B) Slide Crossover® tube alignment guide over the end of burner tube 2 (2). *Note: The Crossover® tube burner ports should face the front of the cookbox.* With Crossover® tube attached, slide burner tube 2 under the guide screw and washer (3).
- C) Put burner tube 3 inside cookbox and pass the front end of tube out through burner tube 3 opening (not pictured). Insert right side of Crossover® tube into Crossover® burner hole in burner tube 3. Slide burner tube 3 under the guide screw and washer (4).
- D) Put burner tube 1 inside cookbox and pass igniter wires and the front end of tube out through burner tube 1 opening (5). Guide wires from burner tube 1 between front cross brace and cookbox and down into cabinet (6).
- E) While holding burner tube 1, insert left side of Crossover® tube into Crossover® burner hole. Slide burner tube 1 under the guide screw and washer (7).

ANNUAL MAINTENANCE

BURNER TUBE CLEANING OR REPLACEMENT (continued)

Reinstall Manifold

You will need: A Phillips screwdriver, two 7/16" spanners.

- A) Align valves with burner tubes. Using two 7/16" spanners, install bolts and nuts that secure manifold to cookbox (1).
- B) With a Phillips screwdriver, install screws and washers that secure manifold to front cross brace (2). If manifold was properly reinstalled, valves will now be fully seated inside burner tubes.

⚠ **CAUTION:** The burner tube openings (3) must be positioned properly over the valve orifices (4).

⚠ **WARNING:** You should check for gas leaks every time you disconnect and reconnect a gas fitting. Refer to CHECKING FOR GAS LEAKS.

- C) Replace cookbox components (not pictured).

Reinstall Control Panel

You will need: A Phillips screwdriver.

- A) Guide the two wires on back of control panel over front cross brace and down into cabinet (5).
- B) Align valve stems with holes in control panel. Position top edge of control panel on tabs of frame assembly. Push control panel down into position.
- C) Fasten control panel with screws.
- D) Place control knobs onto valve stems.
- E) Connect the wires to the igniter module. Snap wires back into wire clips on inside left panel. Refer to "MAINTAINING THE ELECTRONIC CROSSOVER® IGNITION SYSTEM" for proper positioning.

⚠ **WARNING:** Make sure that all parts are assembled and hardware is fully tightened before operating the grill. Your actions, if you fail to follow this product warning, may cause a fire, an explosion, or structural failure resulting in serious personal injury or death as well as damage to property.

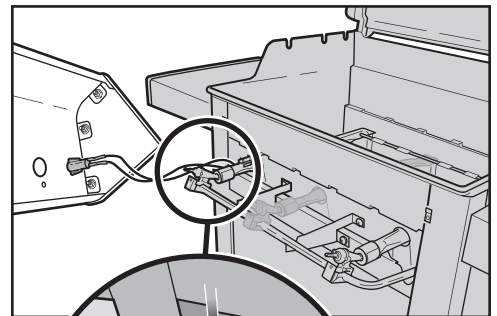
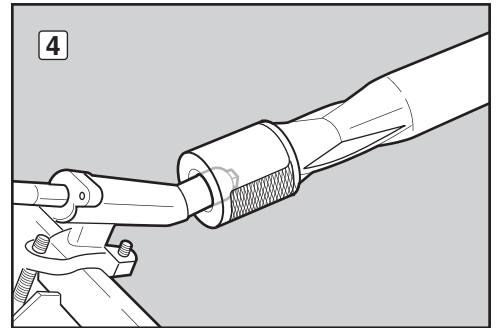
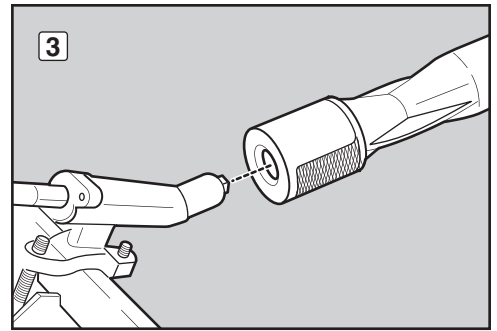
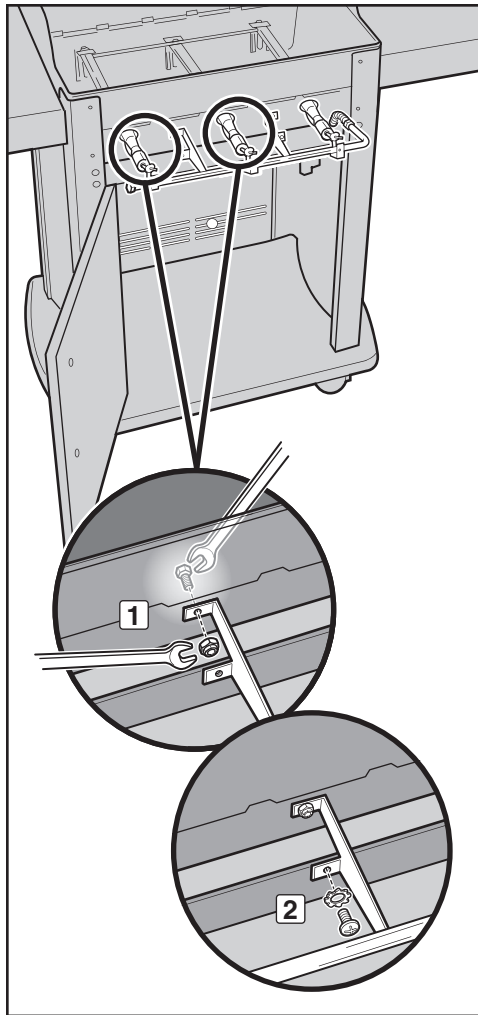

STORAGE

For grills that have been stored for a while, it is important to follow these guidelines:

- The gas must be turned off at the LPG cylinder when the Weber® gas grill is not in use.
- If storing the Weber® gas grill indoors, first DISCONNECT the gas supply and store the LPG cylinder outdoors in a well-ventilated space.
- Do not store a disconnected LPG cylinder in a building, garage, or any other enclosed area.
- If you do not disconnect the LPG cylinder from the Weber® gas grill, be sure to keep both the grill and the cylinder outdoors in a well-ventilated area.
- Check that the areas under the control panel and the slide-out grease tray are free from debris that might obstruct the flow of combustion or ventilation air.

BEAUTIFUL— INSIDE AND OUT

Weber® grill owners take a lot of pride in their grills, and with good reason: our grills are marvels of engineering and design. Flaunt your pride and joy. Keep your grill clean and beautiful—inside and out—by following these routine maintenance steps.

CLEANING THE OUTSIDE OF THE GRILL

To keep the outside of your grill looking its best, use the following guidelines for safe cleaning.

⚠ WARNING: Turn your Weber® gas grill off and wait for it to cool before cleaning it.

Painted, Enamelled and Plastic Surfaces

Use a warm, soapy water solution to clean outside surfaces; then rinse with water.

IMPORTANT: Do not use oven cleaner, abrasive cleaning agents (kitchen cleaning agents), cleaners that contain citrus products, or abrasive cleaning pads on grill or cart surfaces.

Stainless Steel Surfaces

Your grill or its cabinet, lid, and control panel may be made of stainless steel. Wash outside surfaces with a soft cloth and a soap-and-water solution, rinse with water, and wipe dry.

For stubborn particles, a non-metallic brush can be used. Scrub stainless steel surfaces in the direction of the grain.

IMPORTANT: Do not clean stainless steel with anything containing acid, mineral spirits, or xylene. Rinse surfaces well after cleaning. Do not use a wire brush or abrasive cleaners on the stainless steel surfaces of your grill as this will cause scratches. When cleaning stainless steel, be sure to rub/wipe in the direction of the grain.

CLEANING THE INSIDE OF THE GRILL

To keep your grill performing safely and efficiently, it is important to remove any debris and excess grease that may have accumulated on the inside of the grill. Use the following guidelines for safe cleaning.

Inside Lid

Flaking, built-up grease resembles paint flakes. Wipe inside lid with paper towel to prevent grease build-up. Wash inside lid with warm, soapy water; then rinse with water.

Cookbox

Wash inside cookbox with warm, soapy water; then rinse with water.

Cookbox Components

You will need: A stainless steel bristle brush, stiff plastic scraper.

- Scrape and brush the cooking grates with the scraper and brush. Remove the cooking grates and set aside.
- Scrape and brush the Flavorizer® bars with the scraper and brush. As needed, wash them with warm, soapy water; then rinse with water. Remove Flavorizer® bars and set aside.

⚠ CAUTION: Do not clean Flavorizer® bars or cooking grates in a self-cleaning oven.

- Brush any debris off burner tubes and Crossover® tube. Do not enlarge burner ports (openings) running along length of burner and Crossover® tubes (1).
NOTE: When cleaning burner tube 1, avoid damaging the igniter electrode by carefully brushing around it.
- When cleaning is complete, replace the Flavorizer® bars and cooking grates.

Slide-Out Grease Tray

Your grill was built with a grease collection system, which funnels grease away from food and into removable containers.

Check the slide-out grease tray for grease build-up each time you use your grill. Remove excess grease with a plastic scraper (2). Wash the grease tray with a soap-and-water solution and rinse with water.

⚠ CAUTION: Do not line the slide-out grease tray with aluminium foil.

Catch Pan and Disposable Drip Pan

Grease from the slide-out grease tray funnels into a catch pan. Cleaning the catch pan is just as important as cleaning the slide-out grease tray.

Check the catch pan for grease build-up each time you use your grill. Remove excess grease with a plastic scraper (3). Wash the catch pan with warm, soapy water and rinse with water. To keep the catch pan cleaner longer, you can line the catch pan with a Weber® disposable drip pan or with aluminium foil.

⚠ WARNING: Check the slide-out grease tray and catch pan for grease build-up each time before using. Remove excess grease to avoid a grease fire. A grease fire can cause serious bodily injury or damage to property.

HOSE INSPECTION

The hose should be inspected routinely for any signs of cracking (4).

⚠ WARNING: Check hose each time before using grill for nicks, cracking, abrasions or cuts. If the hose is found to be damaged in any way, do not use the grill. Replace using only Weber® authorised replacement hose. Contact the Customer Service Representative in your area using the contact information on our web site. Log onto www.weber.com®.

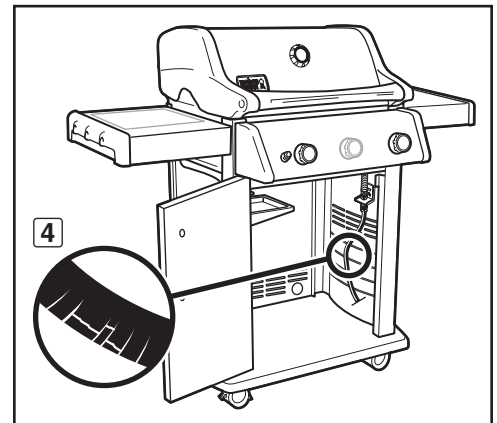
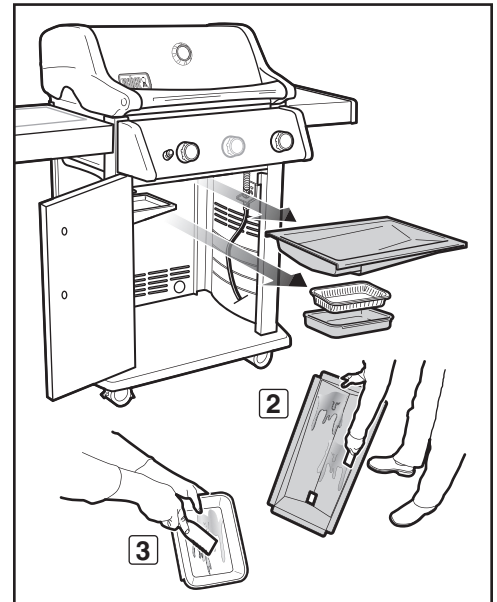
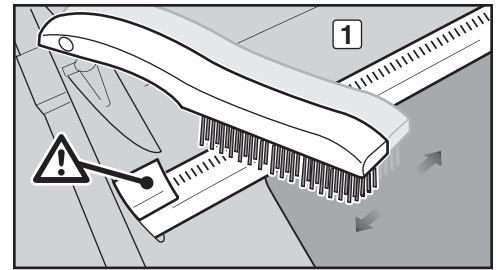

To obtain replacement disposable drip pans, cooking grates and Flavorizer® bars, contact the Customer Service Representative in your area using the contact information on our website. Log onto www.weber.com®.

ROUTINE MAINTENANCE

MAINTAINING THE ELECTRONIC CROSSOVER® IGNITION SYSTEM

The igniter module supplies power to the electronic Crossover® ignition system and the side burner with one igniter button. Whether you are performing routine maintenance or a troubleshooting check on the ignition system, read the following to keep your ignition system working properly.

If the electronic Crossover® ignition system fails to ignite, you'll need to pinpoint where the problem is occurring: with the gas flow or with the electronic ignition system. Begin by attempting to match-light your burners. Refer to "MAIN BURNER IGNITION - Lighting with a Match." If match-lighting is successful, the problem lies in the ignition system.

- Verify that the AA battery (alkaline only) is in good condition and is installed correctly (1). Some batteries have a plastic protective wrap around them. This plastic must be removed before installing battery. Do not confuse this plastic with the battery label.
- Make sure the igniter wires are properly attached to the igniter module. Refer to the "IGNITER MODULE WIRE GUIDE" chart on this page.
- Make sure the ceramic igniter assembly is fully inserted into burner tube igniter channel (2). If properly positioned, you will hear a snap (3).
- Make sure the electronic igniter button is working by listening for clicking and looking for sparks at burner.

If the electronic Crossover® ignition system still fails to ignite, contact the Customer Service Representative in your area using the contact information on our web site. Log onto www.weber.com.

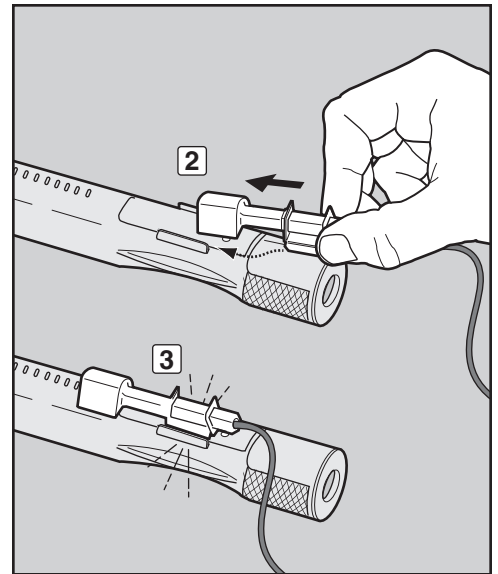
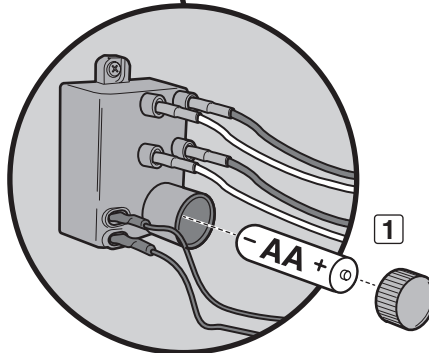
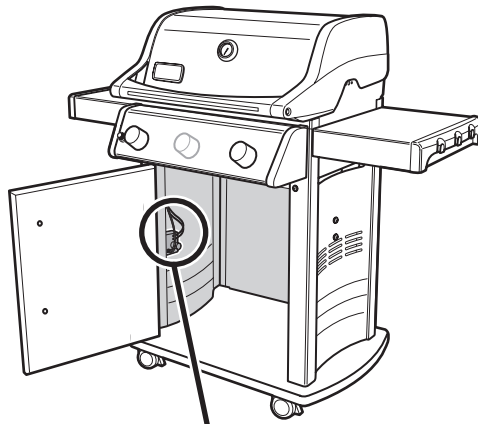

IGNITER MODULE WIRE CHART

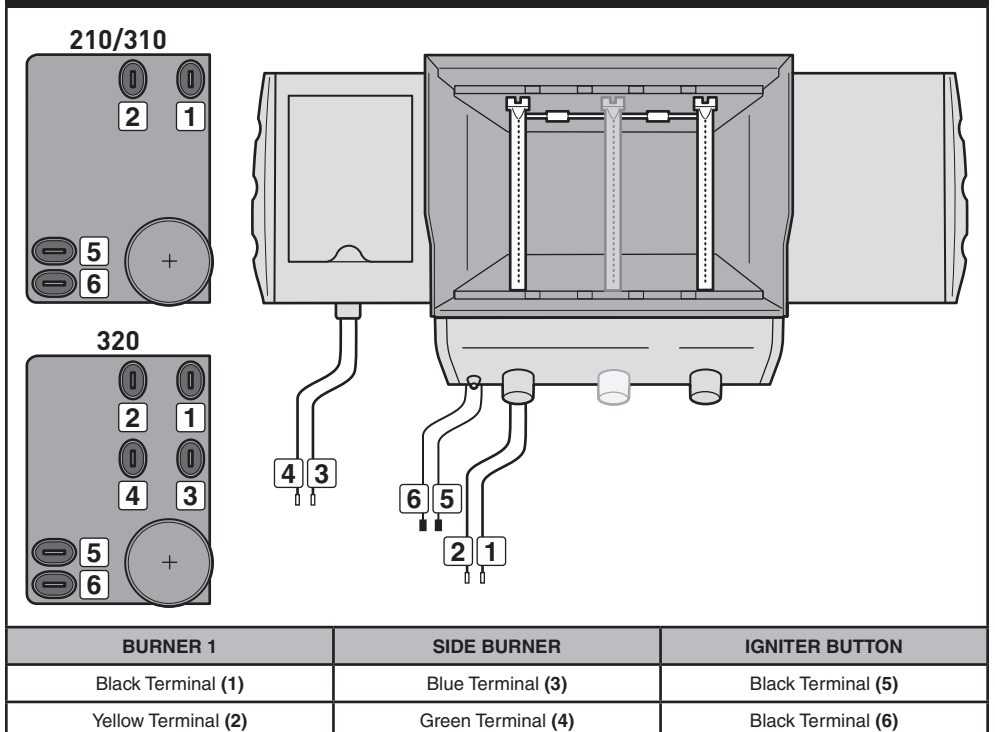

ROUTINE MAINTENANCE (320 MODELS)

CLEANING SIDE BURNER TUBE (320 MODEL)

Remove Side Burner Valve

You will need: A Phillips screwdriver.

- A) Remove the two screws that secure the side burner valve plate to the side burner table (1).
- B) Release the side burner valve from burner tube by gently pulling the assembly forward (2). Exercise care not to kink the corrugated gas line (3).

Clean the Burner Tube

You will need: A torch, a wire (a straightened-out coat hanger), a suitable stainless steel bristle brush.

- A) Look inside the burner tube with a torch (4).
- B) Clean any debris or blockage from the inside of the tube with the wire (5).

Reinstall Side Burner Valve

You will need: A Phillips screwdriver.

- A) Align side burner valve with side burner tube opening (6).

⚠ CAUTION: The side burner tube opening (6) must be positioned properly over the side burner valve orifice (7).

- B) Secure the side burner valve plate to the side burner table using two screws (7).

SIDE BURNER MAINTENANCE

⚠ WARNING: All gas controls and supply valves should be in the off (O) position.

- Make sure black igniter wire and white ground wire are attached to the igniter module inside the base cabinet. Refer to the "IGNITER MODULE WIRE GUIDE."
- Check that the wires are not kinked.
- Make sure the electronic igniter button is working by listening for clicking and looking for sparks at burner.
- The sparks should be a white/blue colour, not yellow.

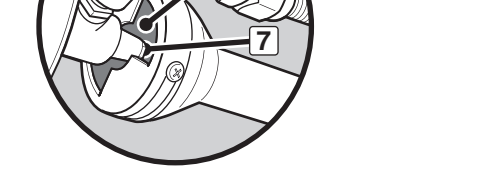
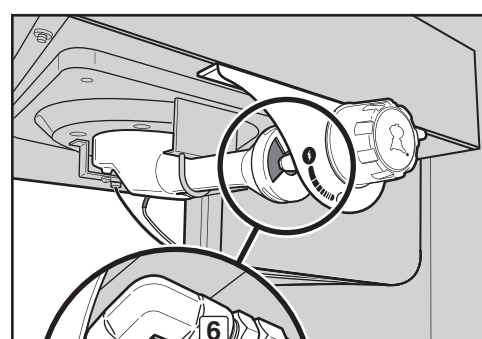
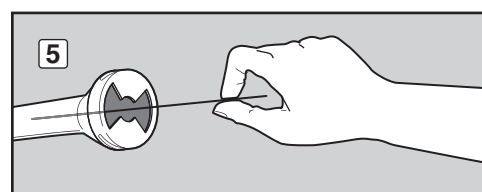
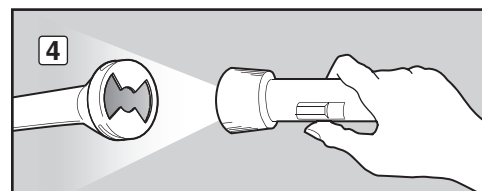
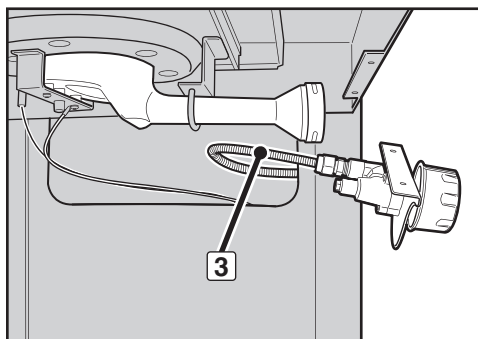
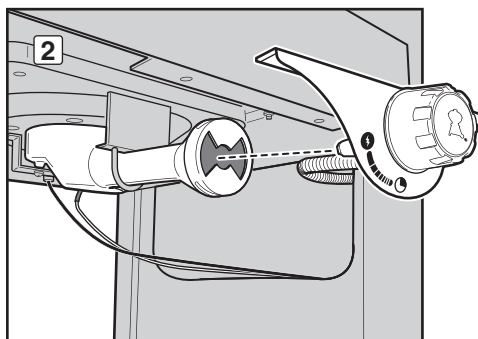
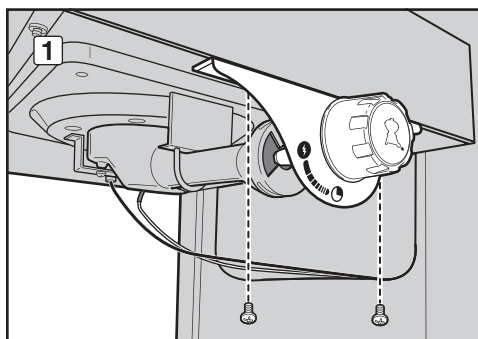

SIDE BURNER EXPLODED VIEW

Side Burner Grate

Side Burner Head

Side Burner Tray

Side Burner Table

Side Burner Control Knob

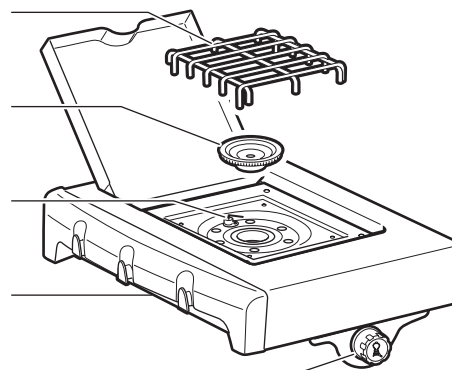

⚠ ATTENTION: This product has been safety-tested and is only certified for use in a specific country. Refer to country designation located on outside of box.

These parts may be gas-carrying or gas-burning components. Please contact Weber-Stephen Products LLC Customer Service Department for genuine Weber-Stephen Products LLC replacement part(s) information.

⚠ WARNING: Do not attempt to make any repair to gas-carrying or gas-burning components without contacting Weber-Stephen Products LLC Customer Service Department. Your actions, if you fail to follow this product warning, may cause a fire or an explosion resulting in serious personal injury or death and damage to property.



This symbol indicates that the product cannot be disposed of with household refuse. For instructions regarding proper disposal of this product in Europe, please visit www.weber.com[®], and contact the importer listed for your country. If you do not have internet access, contact your dealer for the importer's name, address and telephone number.

When you decide to dispose of or discard your barbeque, all electrical components (e.g., rotisserie motor, batteries, ignition module, handle lights) must be removed and disposed of properly according to WEEE. They should be disposed of separately from the barbeque.

WEBER-STEPHEN ÖSTERREICH GMBH

Maria-Theresia-Straße 51
4600 Wels
AUSTRIA
TEL: +43 7242 890 135 0; info-at@weberstephen.com

WEBER-STEPHEN PRODUCTS BELGIUM Sprl

Blarenberglaan 6 Bus 4
Industriezone Noord
BE-2800 Mechelen
BELGIUM
TEL: +32 015 28 30 90; infobelux@weberstephen.com

WEBER-STEPHEN CZ & SK spol. s r.o.

U Hajovny 246
25243 Průhonice
CZECH REPUBLIC
TEL: +42 267 312 973; info-cz@weberstephen.com

WEBER-STEPHEN NORDIC ApS

Bøgildsmindevej 23, DK-9400 Nørresundby
DANMARK
TEL: +45 99 36 30 10; info@weberstephen.dk

WEBER-STEPHEN NORDIC MIDDLE EAST

Ras Al Khaimah FTZ
P.O. Box 10559
UNITED ARAB EMIRATES
TEL: +971 4 360 9256; info@weberstephen.ae

WEBER-STEPHEN FRANCE SAS

Eragny sur Oise – BP 80322
95617 Cergy Pontoise Cedex
FRANCE
TÉL: +33 810 19 32 37
service.consommateurs@weberstephen.com

WEBER-STEPHEN DEUTSCHLAND GmbH

Rheinstraße 194
55218 Ingelheim
DEUTSCHLAND
TEL: +49 6132 8999 0; info-de@weberstephen.com

WEBER-STEPHEN NETHERLANDS B.V.

Tsjükemarwei 12
8521 NA Sint Nicolaasga
Postbus 18
8520 AA Sint Nicolaasga
NETHERLANDS
TEL: +31 513 4333 22; info@weberbarbecues.nl

JARN & GLER WHOLESAL EHF

Skutuvogur 1H
1-104 Reykjavik
ICELAND
TEL: +354 58 58 900

D&S IMPORTS

14 Shenkar Street
Petach, Tikva 49001
ISRAEL
TEL: +972 392 41119; info@weber.co.il

WEBER-STEPHEN PRODUCTS ITALIA Srl

Centro Polifunzionale "Il Pioppo"
Viale della Repubblica 46
36030 Povolara di Dueville – Vicenza
ITALY
TEL: +39 0444 360 590; info-italia@weberstephen.com

WEBER-STEPHEN POLSKA Sp. z o.o.

Ul. Trakt Lubelski 153
04-766 Warszawa
POLSKA
TEL: +48 22 392 04 69; info-pl@weberstephen.com

GALACTEX OUTDOOR (PTY) LTD.

141-142 Hertz Draai
Meadowdale, Edenvale
Gauteng
SOUTH AFRICA
TEL: +27 11 454 2369; info@weber.co.za

WEBER-STEPHEN IBERICA Srl

Avda. de les Corts Catalanes 9-11 -
Despacho 10 B
E-08173 Sant Cugat del Vallès
Barcelona
SPAIN
TEL: +34 93 584 40 55; infoiberica@weberstephen.com

WEBER-STEPHEN SCHWEIZ GMBH

Talackerstr. 89a
8404 Winterthur
SWITZERLAND
TEL: +41 52 24402 50; info-ch@weberstephen.com

WEBER-STEPHEN PRODUCTS

(U.K.) LIMITED

The Four Columns,
Broughton Hall Business Park
Skipton, North Yorkshire BD23 3AE
UNITED KINGDOM
TEL: +44 01756 692611;
Customerservicenwe@weberstephen.com

WEBER-STEPHEN PRODUCTS LLC

200 East Daniels Road
Palatine, IL 60067-6266
USA
TEL: 847 934 5700; support@weberstephen.com

OOO WEBER-STEPHEN Vostok

142784 Moscow Region,
Leninskiy District
Rumyantsevo Village
Building 1
RUSSIA
TEL: +7 495 973 16 49; info.ru@weberstephen.com

WEBER-STEPHEN MAGYARORSZÁG KFT.

1138 Budapest, Váci út 186.
HUNGARY
TEL: +36 70 / 70-89-813; info-hu@weberstephen.com

For Republic of Ireland, please contact:
Weber-Stephen Products (U.K.) Limited.

For other eastern European countries,
such as ROMANIA, SLOVENIA, CROATIA,
TURKEY, or GREECE, please contact:
Weber-Stephen Deutschland GmbH,
info-EE@weberstephen.com.

For Baltic States, please contact:
Weber-Stephen Nordic ApS.



WEBER-STEPHEN PRODUCTS LLC

www.weber.com[®]